

Homelite®

OPERATOR'S MANUAL MANUEL D'UTILISATION MANUAL DEL OPERADOR

UT10522, UT10526 / 20 in. 46cc Chain Saw

Scie à chaîne de 46 cc de 50 cm (20 po)

Motosierra de 50 cm (20 pulg.), 46 cc

UT10519 / 18 in. 46cc Chain Saw

Scie à chaîne de 46 cc de 45 cm (18 po)

Motosierra de 45 cm (18 pulg.), 46 cc

(ALL VERSIONS)

(TOUTES LES VERSIONS)

(TODAS LAS VERSIONES)

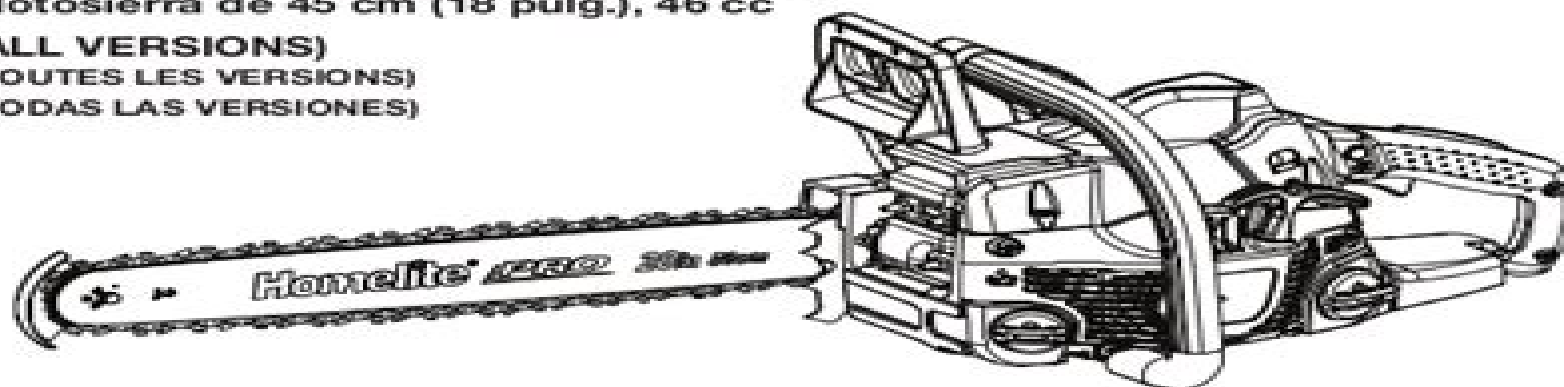

Your chain saw has been engineered and manufactured to Homelite's high standard for dependability, ease of operation, and operator safety. When properly cared for, it will give you years of rugged, trouble-free performance.

WARNING: To reduce the risk of injury, the user must read and understand the operator's manual before using this product.

Thank you for buying a Homelite product.

SAVE THIS MANUAL FOR FUTURE REFERENCE

Cette scie à chaîne a été conçue et fabriquée conformément aux strictes normes de fiabilité, simplicité d'emploi et sécurité d'utilisation de Homelite. Correctement entretenue, elle vous donnera des années de fonctionnement robuste et sans problème.

AVERTISSEMENT : Pour réduire les risques de blessures, l'utilisateur doit lire et veiller à bien comprendre le manuel d'utilisation avant d'employer ce produit.

Merci d'avoir acheté un produit Homelite.

**CONSERVER CE MANUEL POUR
FUTURE RÉFÉRENCE**

Su motosierra ha sido diseñada y fabricada de conformidad con las estrictas normas de Homelite para brindar fiabilidad, facilidad de uso y seguridad para el operador. Con el debido cuidado, le brindará muchos años de sólido y eficiente funcionamiento.

ADVERTENCIA: Para reducir el riesgo de lesiones, el usuario debe leer y comprender el manual del operador antes de usar este producto.

Le agradecemos la compra de un producto Homelite.

**GUARDE ESTE MANUAL PARA
FUTURAS CONSULTAS**

Ut10530 Repair Manual

Larry Holt, John Harold Haynes



Ut10530 Repair Manual:

Mitsubishi Eclipse & Eagle Talon Automotive Repair Manual Alan Ahlstrand, John Harold Haynes, 2002-01-01 Inside this manual the reader will learn to do routine maintenance tune up procedures engine repair along with aspects of your car such as cooling and heating air conditioning fuel and exhaust emissions control ignition brakes suspension and steering electrical systems wiring diagrams

Subaru Automotive Repair Manual Larry Holt, John Harold Haynes, 1990 Covers Subaru 2WD and 4WD sedan hatchback station wagon XT and Brat pick up 1980 thru 1989 With step by step procedures

Ut10530 Repair Manual Book Review: Unveiling the Magic of Language

In an electronic era where connections and knowledge reign supreme, the enchanting power of language has become more apparent than ever. Its ability to stir emotions, provoke thought, and instigate transformation is really remarkable. This extraordinary book, aptly titled "**Ut10530 Repair Manual**," written by a very acclaimed author, immerses readers in a captivating exploration of the significance of language and its profound effect on our existence. Throughout this critique, we will delve into the book's central themes, evaluate its unique writing style, and assess its overall influence on its readership.

<https://movement.livewellcolorado.org/About/scholarship/HomePages/4024%20June%202014%20Paper%201.pdf>

Table of Contents Ut10530 Repair Manual

1. Understanding the eBook Ut10530 Repair Manual
 - The Rise of Digital Reading Ut10530 Repair Manual
 - Advantages of eBooks Over Traditional Books
2. Identifying Ut10530 Repair Manual
 - Exploring Different Genres
 - Considering Fiction vs. Non-Fiction
 - Determining Your Reading Goals
3. Choosing the Right eBook Platform
 - Popular eBook Platforms
 - Features to Look for in an Ut10530 Repair Manual
 - User-Friendly Interface
4. Exploring eBook Recommendations from Ut10530 Repair Manual
 - Personalized Recommendations
 - Ut10530 Repair Manual User Reviews and Ratings
 - Ut10530 Repair Manual and Bestseller Lists
5. Accessing Ut10530 Repair Manual Free and Paid eBooks

- Ut10530 Repair Manual Public Domain eBooks
 - Ut10530 Repair Manual eBook Subscription Services
 - Ut10530 Repair Manual Budget-Friendly Options
6. Navigating Ut10530 Repair Manual eBook Formats
 - ePub, PDF, MOBI, and More
 - Ut10530 Repair Manual Compatibility with Devices
 - Ut10530 Repair Manual Enhanced eBook Features
 7. Enhancing Your Reading Experience
 - Adjustable Fonts and Text Sizes of Ut10530 Repair Manual
 - Highlighting and Note-Taking Ut10530 Repair Manual
 - Interactive Elements Ut10530 Repair Manual
 8. Staying Engaged with Ut10530 Repair Manual
 - Joining Online Reading Communities
 - Participating in Virtual Book Clubs
 - Following Authors and Publishers Ut10530 Repair Manual
 9. Balancing eBooks and Physical Books Ut10530 Repair Manual
 - Benefits of a Digital Library
 - Creating a Diverse Reading Collection Ut10530 Repair Manual
 10. Overcoming Reading Challenges
 - Dealing with Digital Eye Strain
 - Minimizing Distractions
 - Managing Screen Time
 11. Cultivating a Reading Routine Ut10530 Repair Manual
 - Setting Reading Goals Ut10530 Repair Manual
 - Carving Out Dedicated Reading Time
 12. Sourcing Reliable Information of Ut10530 Repair Manual
 - Fact-Checking eBook Content of Ut10530 Repair Manual
 - Distinguishing Credible Sources
 13. Promoting Lifelong Learning
 - Utilizing eBooks for Skill Development

- Exploring Educational eBooks
14. Embracing eBook Trends
- Integration of Multimedia Elements
 - Interactive and Gamified eBooks

Ut10530 Repair Manual Introduction

In today's digital age, the availability of Ut10530 Repair Manual books and manuals for download has revolutionized the way we access information. Gone are the days of physically flipping through pages and carrying heavy textbooks or manuals. With just a few clicks, we can now access a wealth of knowledge from the comfort of our own homes or on the go. This article will explore the advantages of Ut10530 Repair Manual books and manuals for download, along with some popular platforms that offer these resources. One of the significant advantages of Ut10530 Repair Manual books and manuals for download is the cost-saving aspect. Traditional books and manuals can be costly, especially if you need to purchase several of them for educational or professional purposes. By accessing Ut10530 Repair Manual versions, you eliminate the need to spend money on physical copies. This not only saves you money but also reduces the environmental impact associated with book production and transportation. Furthermore, Ut10530 Repair Manual books and manuals for download are incredibly convenient. With just a computer or smartphone and an internet connection, you can access a vast library of resources on any subject imaginable. Whether you're a student looking for textbooks, a professional seeking industry-specific manuals, or someone interested in self-improvement, these digital resources provide an efficient and accessible means of acquiring knowledge. Moreover, PDF books and manuals offer a range of benefits compared to other digital formats. PDF files are designed to retain their formatting regardless of the device used to open them. This ensures that the content appears exactly as intended by the author, with no loss of formatting or missing graphics. Additionally, PDF files can be easily annotated, bookmarked, and searched for specific terms, making them highly practical for studying or referencing. When it comes to accessing Ut10530 Repair Manual books and manuals, several platforms offer an extensive collection of resources. One such platform is Project Gutenberg, a nonprofit organization that provides over 60,000 free eBooks. These books are primarily in the public domain, meaning they can be freely distributed and downloaded. Project Gutenberg offers a wide range of classic literature, making it an excellent resource for literature enthusiasts. Another popular platform for Ut10530 Repair Manual books and manuals is Open Library. Open Library is an initiative of the Internet Archive, a non-profit organization dedicated to digitizing cultural artifacts and making them accessible to the public. Open Library hosts millions of books, including both public domain works and contemporary titles. It also allows users to borrow digital copies of certain books for a limited period, similar to a library lending system. Additionally, many universities and educational institutions have their own digital

libraries that provide free access to PDF books and manuals. These libraries often offer academic texts, research papers, and technical manuals, making them invaluable resources for students and researchers. Some notable examples include MIT OpenCourseWare, which offers free access to course materials from the Massachusetts Institute of Technology, and the Digital Public Library of America, which provides a vast collection of digitized books and historical documents. In conclusion, Ut10530 Repair Manual books and manuals for download have transformed the way we access information. They provide a cost-effective and convenient means of acquiring knowledge, offering the ability to access a vast library of resources at our fingertips. With platforms like Project Gutenberg, Open Library, and various digital libraries offered by educational institutions, we have access to an ever-expanding collection of books and manuals. Whether for educational, professional, or personal purposes, these digital resources serve as valuable tools for continuous learning and self-improvement. So why not take advantage of the vast world of Ut10530 Repair Manual books and manuals for download and embark on your journey of knowledge?

FAQs About Ut10530 Repair Manual Books

What is a Ut10530 Repair Manual PDF? A PDF (Portable Document Format) is a file format developed by Adobe that preserves the layout and formatting of a document, regardless of the software, hardware, or operating system used to view or print it. **How do I create a Ut10530 Repair Manual PDF?** There are several ways to create a PDF: Use software like Adobe Acrobat, Microsoft Word, or Google Docs, which often have built-in PDF creation tools. Print to PDF: Many applications and operating systems have a "Print to PDF" option that allows you to save a document as a PDF file instead of printing it on paper. Online converters: There are various online tools that can convert different file types to PDF. **How do I edit a Ut10530 Repair Manual PDF?** Editing a PDF can be done with software like Adobe Acrobat, which allows direct editing of text, images, and other elements within the PDF. Some free tools, like PDFescape or Smallpdf, also offer basic editing capabilities. **How do I convert a Ut10530 Repair Manual PDF to another file format?** There are multiple ways to convert a PDF to another format: Use online converters like Smallpdf, Zamzar, or Adobe Acrobats export feature to convert PDFs to formats like Word, Excel, JPEG, etc. Software like Adobe Acrobat, Microsoft Word, or other PDF editors may have options to export or save PDFs in different formats. **How do I password-protect a Ut10530 Repair Manual PDF?** Most PDF editing software allows you to add password protection. In Adobe Acrobat, for instance, you can go to "File" -> "Properties" -> "Security" to set a password to restrict access or editing capabilities. Are there any free alternatives to Adobe Acrobat for working with PDFs? Yes, there are many free alternatives for working with PDFs, such as: LibreOffice: Offers PDF editing features. PDFsam: Allows splitting, merging, and editing PDFs. Foxit Reader: Provides basic PDF viewing and

editing capabilities. How do I compress a PDF file? You can use online tools like Smallpdf, ILovePDF, or desktop software like Adobe Acrobat to compress PDF files without significant quality loss. Compression reduces the file size, making it easier to share and download. Can I fill out forms in a PDF file? Yes, most PDF viewers/editors like Adobe Acrobat, Preview (on Mac), or various online tools allow you to fill out forms in PDF files by selecting text fields and entering information. Are there any restrictions when working with PDFs? Some PDFs might have restrictions set by their creator, such as password protection, editing restrictions, or print restrictions. Breaking these restrictions might require specific software or tools, which may or may not be legal depending on the circumstances and local laws.

Find Ut10530 Repair Manual :

4024 june 2014 paper 12

box cake cookie recipe

20kia cerato repair manual

[bmw 850i manual transmission for sale](#)

[porsche 911 carrera 1995 repair service manual](#)

business studies september paper 2014 grade 10

1997 ford crown victoria workshop oem service repair manual

managerial accounting 2final exam solutions

key of the keplian secrets of the witch world

2013 maths ana 2014 memorandum grade 9

[2007 chevrolet impala engine diagram](#)

[2009 audi tt coil over kit manual](#)

2014 exemplar economics quesstion paper

1996 skandic 380 manual

panasonic dmp bdt100 bdt105 service manual repair guide

Ut10530 Repair Manual :

law no 13 of 1997 with respect to the civil defence - Jun 21 2022

web 4 taking preventive measures to protect the population wealth and public and private establishments in time of peace and war 5 coordination with the ministries and relevant departments to implement civil defence measures

qatar s interior ministry launches civil defence technical requirements - May 01 2023

web april 6 2022 image credits the peninsular qatar the ministry of interior represented by the general directorate of civil defence gdc d has launched the civil defence technical requirements guide 2022 it was launched in a ceremony organized in the presence of a number of officials in the ministry

moi launches civil defence technical requirements guide 2022 - Feb 27 2023

web mar 4 2022 the ministry of interior moi represented by the general directorate of civil defence gdc d yesterday launched the civil defence technical requirements guide 2022 putting in place an updated mechanism to combat emergencies and adding more features to the existing guidelines

civil defence of qatar launches updated fire and life safety - Aug 24 2022

web mar 15 2022 the general directorate of civil defence has launched the updated fire and life safety manual on 3 march 2022 in qatar this is to help aid fire prevention suppression and protection of life in the event of a fire at a function

qatar fire and life safety manual launched lexisnexis middle - Jan 29 2023

web mar 7 2022 the peninsula 4 march 2022 qatar s general directorate of civil defence has announced it has launched an updated fire and life safety manual the manual is contained in the civil defence technical requirements manual 2022 it includes all of the engineering requirements related to prevention systems in buildings

moi launches civil defence technical requirements guide 2022 - Jun 02 2023

web brig hamad othman al duhaimi the ministry of interior moi represented by the general directorate of civil defence gdc d yesterday launched the civil defence technical requirements

qcd fire safety guidelines - Aug 04 2023

web general directorate of civil defence ministry of interior state of qatar building plan fire and life safety guidelines revisions 2015 volume i i apartment buildings ii hotel buildings iii building height requirements building area requirements general directorate of civil defence ministry of interior state of qatar

law no 13 of 1997 with respect to the civil defence - Apr 19 2022

web jan 12 1997 1 workers in the field of civil defence not working in the police force shall be subject to the rules of discipline and sanctions in place for those working in the police force in accordance with the provisions of the military service law promulgated by the decree in law no 31 of 2006

moi qatar ministry of interior qatar ██████████ ██████ - Oct 06 2023

web safety measures in qatar statistics department news introduction the state gives highest care for internal security as it is the pillar of the stability and spends maximum efforts to provide security safety and peace of mind for citizens and residents

updated civil defence technical requirements manual launched - Mar 31 2023

web mar 4 2022 updated civil defence technical requirements manual launched 04 03 2022 nation 649866 a webmaster
tribune news network doha the general directorate of civil defence launched its updated fire and life safety manual at a
function held at the officers club of the directorate yesterday

qcdd general fire safety requirements guideline annexes revisions 2015 - Sep 24 2022

web qatar civil department regulations 2015 revision pdf qcdd general fire safety requirements guideline annexes revisions
2015 samir rabia academia edu academia edu no longer supports internet explorer

fire detection and alarm systems fdas a brief guide to qatar - Feb 15 2022

web jan 4 2018 qatar civil defence fire safety standards series qcd fss kahramaa and ashghal regulations nfpa 1 fire code
nfpa 14 standard for installation of standpipe and hose systems

civil defence launches updated fire and life safety manual - Dec 28 2022

web apr 3 2022 the general directorate of civil defence launched the updated fire and life safety manual at a function held
in the officers club of the directorate yesterday

moi launches civil defense technical requirements guide 2022 - Sep 05 2023

web doha march 03 qna the ministry of interior represented by the general directorate of civil defense has launched on
thursday the civil defense technical requirements guide 2022 in a ceremony organized in the presence of a number of
officials in the ministry

fire prevention department general directorate of civil defence - May 21 2022

web nfpa standards and qatar civil defence requirements declare that the equipment and all devices to be used for fire fire
fighting shall be listed for such purposes and approved type by qcdd 2 0 plans and documents to be submitted a detailed
design report a narrative report that provides the following where applicable

qcd fire and life safety guideline rev2015 academia edu - Mar 19 2022

web qatar civil defense fire and life safety guideline rev 2015 qatar civil defense fire and life safety guideline rev 2015 qatar
civil department regulations 2015 revision download free pdf view pdf code of practice for fire safety in buildings in hong
kong da meng meng

release of the updated civil defence qatar civil defence - Oct 26 2022

web the civil defence technical requirements manual 2022 is the result of the efforts made by members of the committee
assigned of preparing the manual for more than two years the manual includes all engineering requirements related to
prevention systems in buildings said brigadier hamad othman al duhaimi director general of civil defense

qatar civil defence launches updated fire and life safety manual - Nov 26 2022

web mar 8 2023 qatar s civil defence has launched an updated fire and safety manual to help aid fire prevention

suppression and protection of life in the event of a fire the new manual and guidance was launched by the general directorate at a function held in the officers club of the directorate on thursday 3rd march

qcd guideline annex 2022 pdf fire safety mosque scribd - Jul 23 2022

web qcd guideline annex 2022 view presentation slides online qatar civil defense regulation 2022

ministry launches civil defense technical requirements guide - Jul 03 2023

web mar 3 2022 the peninsula doha the ministry of interior represented by the general directorate of civil defense has launched the civil defense technical requirements guide 2022

artist management contract artist management agreement - Jul 02 2022

web aug 11 2023 an artist management contract protects you and your artist learn what an artist management contract should contain 240 261 7630 info artistmanagementeducation com once you have a handle on some of these important items you can then use an artist management contract template or

artist management agreement form printable blank pdf online - Dec 27 2021

web all in one pdf converter convert and save your artist management agreement form as pdf pdf presentation pptx image jpeg spreadsheet xlsx or document docx transform it to the fillable template for one click reusing

35 useful artist management contract templates - Nov 06 2022

web essentials of an artist management contract template following are some important components of a valid artist management contract template 1 manager s exclusivity it is very common for the managers to manage more than one artists at the same time so if a manager is managing the other artists as well this fact must be clearly mentioned

5 free artist manager contract templates customize and edit - Sep 04 2022

web sep 11 2022 in this blog post we are giving away 5 free artist manager contract templates that you can use to get started these are basic contracts which can be customized to fit the needs of bands and solo musical but

download artist management contract templates for free - Mar 30 2022

web download artist management contract templates for free formtemplate offers you hundreds of resume templates that you can choose the one that suits your work

free 10 artist management contract templates in pdf ms - Oct 05 2022

web download artist management contract template details file format ms word pages

5 free artist manager contract templates customize and edit - Jun 13 2023

web sep 11 2022 if so industry hackerz has got you in this blog post we are giving away 5 free artist manager contract templates that you can use to get started these are basic contracts that can be customized to fit the needs of bands and solo musicians but cover key elements of music management

artists management contract template download printable pdf - Jun 01 2022

web download fill in and print artists amp 039 management contract template pdf online here for free artists amp 039

management contract template is often used in contract template

50 artist management contract templates ms word - Aug 15 2023

web 1 artist management contracts 2 types of artist management contracts 3 management contract templates 4 basic parts of an artist management contract 5 talent management contract templates 6 music manager contracts 7 what to keep in mind before signing an artist management contract

20 sample artist management agreement templates in pdf - Jan 28 2022

web 20 sample artist management agreement templates artist management agreement download now artist agent agreement

download now non exclusive agreement for management services download now artist management agreement example

download now sample artist management agreement download now exclusive management

18 free artist management contract templates word pdf - Jul 14 2023

web this post will discuss the details of an artist management contract the essential elements that should be included and list some of the many types of artist management contracts the post also addresses some of the common frequently asked questions many artists and managers have about these types of contracts

21 sample artist management contracts in pdf ms word - Aug 03 2022

web download now artist s management contract download now sample management contract download now artist and tour

management contract download now artist management contract download now artist exclusive contract download now

performance contract download now artist management contract in word download

management contract for artist fill out sign online dochub - Apr 11 2023

web an artist management agreement is used by a personal manager to contract with a recording and performing musical artist to set the terms for managing the artist s career the manager receives a percentage of all the income generated by the artist for the management services provided

artist management microsoft contract word template pdfsimpli - Feb 26 2022

web fill out the artist management microsoft contract word template form for free keep it simple when filling out your artist management microsoft contract word template and use pdfsimpli don t delay try for free today

free 10 artist management contract templates in pdf ms - Feb 09 2023

web artist management contract create artist contract template sample artist management conclude template artist

management contract screen simple execution contract template expert leitung contract in word art management drafting

sample recording artist leitung agreement example artist management contract patterns

free 10 artist management contract templates in pdf ms - Apr 30 2022

web artist management contract model artist contract template pattern artist management contract original artist management contract template simple performance contract template painter management enter in phrase artist management contract sample recording artist management contract example

artist management contract template - Jan 08 2023

web download this artist management contract template design in google docs word apple pages format easily editable printable downloadable does your artist agency need a document that can legally bind an artist to certain management services

how to create an artist management contract template net - Dec 07 2022

web 1 artist management contract template 2 artist contract template 3 artist commission contract template 4 artist producer contract template 5 artist booking agent contract template 6 artist management contract template 7 simple management contract sample 8 exclusive management agreement agreement

artist management contract template contract templates indy - Mar 10 2023

web contractors for independent artist management get access to a great method to get started on establishing a contract for their artist management business via the use of indy contract templates the templates are easy to use and may be customized to meet your particular requirements

6 artist management contract templates word pdf google - May 12 2023

web 6 artist management contract templates word google docs pdf an artist management contract can be defined as a contract between an artist and a manager to avail management services contracts are agreements that are legally bound and give details of the deal between the parties involved and also the details of all the parties

the slate roof bible everything you need to know about the - Aug 05 2022

web the slate roof bible everything you wanted to know about slate roofs including how to keep them alive for centuries by jenkins joseph c publication date 1997 topics slate

the slate roof bible roofing contractor - Oct 07 2022

web joseph jenkins inc our books and publications slate roofing snow guards soldering slate roof bible 3rd edition the 3rd edition of the slate roof bible hardcover with

buy the slate roof bible understanding installing and - Dec 09 2022

web slate roof bible 2nd edition table of contents author joseph jenkins subject slate roof bible 2nd edition table of contents keywords slate roof bible slate roof

the slate roof bible understanding installing and restoring the - Aug 17 2023

web the slate roof bible understanding installing and restoring the world s finest roof jenkins joseph c amazon sg books

the slate roof bible understanding installing and - Oct 19 2023

web oct 1 2003 the award winning slate roof bible 2nd edition has over 350 color photographs of slate and slate roofs from around the world and a total of over 600 photos illustrations graphs charts diagrams maps etc jenkins down home style converts

the slate roof bible jenkins joseph c amazon sg books - Apr 01 2022

web exceptionally well written illustrated organized and presented the slate roof bible everything you need to know about the world s finest roof is especially

the slate roof bible understanding installing and re - Mar 12 2023

web completely revised greatly expanded and updated version of the award winning the slate roof bible with 21 chapters including six that are new international roof slate

the slate roof bible understanding installing and restoring the - Jan 10 2023

web completely revised greatly expanded and updated version of the award winning the slate roof bible with 21 chapters including six that are new international roof slate

the slate roof bible atlas preservation - Jun 03 2022

web the slate roof bible understanding installing and restoring the world s finest roof the slate roof bible 2nd edition by joseph jenkins isbn 10 0964425815 isbn 13

slate roof bible 3rd edition page one jenkinspublishing com - Sep 06 2022

web joseph jenkins climbed on his first slate roof in 1968 authored the first edition of the slate roof bible in 1997 and published the second edition in 2003 both editions received

the slate roof bible joseph c jenkins google books - Feb 11 2023

web completely revised greatly expanded and updated version of the award winning the slate roof bible with 21 chapters including six that are new international roof slate

the slate roof bible everything you wanted to know about slate - Jul 04 2022

web slate roof bible 3rd edition published june 2016 hardcover full color 374 pages nearly 800 illustrations joseph jenkins climbed on his first slate roof

the slate roof bible everything you by jenkins joseph c - Sep 18 2023

web hardcover july 15 2016 joseph jenkins climbed on his first slate roof in 1968 authored the first edition of the slate roof bible in 1997 and published the second edition in

the slate roof bible everything you need to know about the - Apr 13 2023

web completely revised greatly expanded and updated version of the award winning the slate roof the slate roof bible understanding installing and restoring the world s

the slate roof bible chelsea green publishing - Jun 15 2023

web dec 8 2020 the slate roof bible everything you need to know about the world s finest roof print replica kindle edition by joseph jenkins author format kindle

the slate roof bible everything you need to know about the - May 14 2023

web the slate roof bible everything you need to know about the world s finest roof 3rd edition jenkins joseph c amazon sg books

the slate roof bible contents - Nov 08 2022

web may 9 2016 mr jenkins himself now 63 has collected a lifetime of experience about slate roofs and published it all in a beautiful hard cover full color life work the slate roof

slate roof bible 3rd edition roofing books slate roof - Jul 16 2023

web mar 16 2023 joseph jenkins climbed on his first slate roof in 1968 authored the first edition of the slate roof bible in 1997 and published the second edition in 2003 both

university of vermont facilities design standards division 07 - Jan 30 2022

the slate roof bible understanding installing and abebooks - May 02 2022

web hello sign in account lists returns orders cart

slate roof bible ebook roofing books slate roof warehouse - Feb 28 2022

web b replaced slate shall match the existing building slate 2 reference standards a to be specified by design professional b jenkins joseph c the slate roof bible joseph