

Parts Breakdown Power Head Assembly And Accessories – All Models

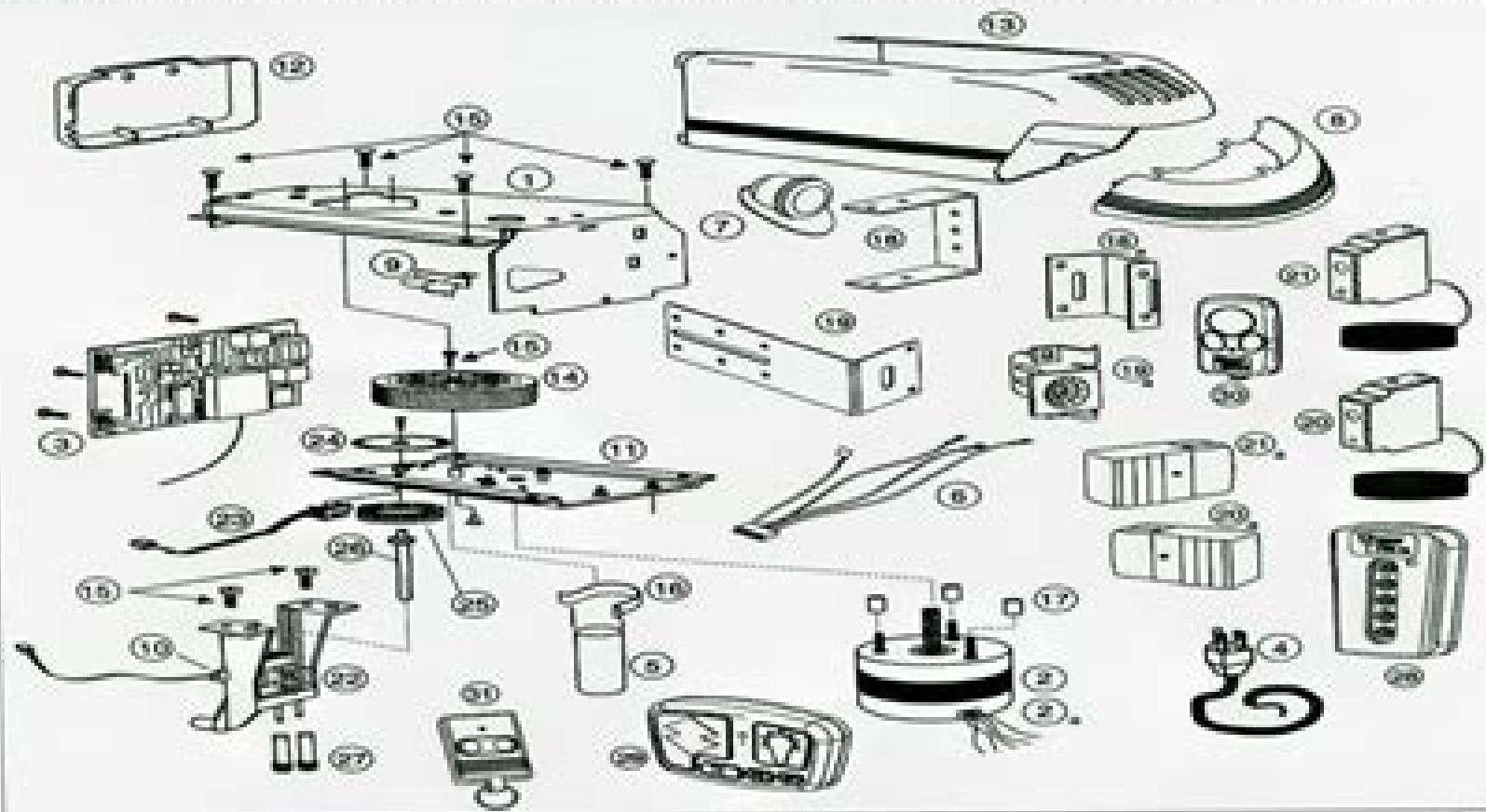

#	Part #	Description	Per Unit	#	Part #	Description	# Per Unit
1	157157	Frame	1	18	157166	Wired Sensor Mounting Bracket	2
2	292123 or 291385	Motor – 1/2 H.P.	1	18a	157159	Wireless Sensor Wall Mounting Bracket	2
2a	291386 or 291387	Motor – 1/3 H.P.	1	19	157165	Wired Sensor Sliding Bracket	2
3	306132	Motor Control Board (all models)	1	19a	157162	Wireless Sensor Mounting Bracket	2
4	306364	Power Supply Cord	1	20	260597	Wired Receiving Unit	1
5	260570	Capacitor – 1/2 H.P.	1	20a	260598	Wireless Transponder Unit	1
6	306486	Wiring Harness	1	21	260600	Wired Sending Unit	1
7	269028	Light Socket	1	21a	260599	Wireless Sending Unit	1
8	260552	Lens	1	22	262092	Limit Assembly (includes items #10, 27 & 28)	1
9	262994	MOV Surge Suppressor	1	23	249321	LED Interrupter	1
10	252993	Limit Switch	1	24	260556	Limit Driver Gear	1
11	252126	Sub-Frame	1	25	157039	Interrupter Disk	1
12	260532	End-Gap	1	26	260557	Shaft, Limit Driver	1
13	260530	Housing	1	27	157055	Limit Adjuster	2
14	260525	Gear, Driver	1	28	306134	5 Button Wireless Keyless Entry	1
15	251248	Screw 1/4-20 x 3/8	7	29	302090	5 Button Wall-station Transmitter	1
16	301675	Capacitor Clamp	1	30	302083	3 Button Mini/Visor Transmitter	1
17	157495	5/16" Motor Spacers	3	31	299254	2 Button Mini Transmitter	1

Stanley Model 1200 Manual

National Library of Medicine (U.S.)



Stanley Model 1200 Manual:

Poor's ,1925 *Catalog of Copyright Entries. Third Series* Library of Congress. Copyright Office,1978 **Report of the Minister of Education** Ontario. Department of Education,1908 **Sessional Papers - Legislature of the Province of Ontario** Ontario. Legislative Assembly,1912 **The Commercial Motor** ,1914 **Financial Report of the Board of Curators of the University of Missouri to the ... General Assembly** University of Missouri. Board of Curators,1909

Boys' Life ,1928-01 Boys Life is the official youth magazine for the Boy Scouts of America Published since 1911 it contains a proven mix of news nature sports history fiction science comics and Scouting **Books and Pamphlets, Including Serials and Contributions to Periodicals** Library of Congress. Copyright Office,1977 Patterson's American Educational Directory Homer L. Patterson,1929 **Road and Track** ,1970 **Directory of the Illinois Schools** ,1915

Circular Illinois. Office of the Superintendent of Public Instruction,1918 Patterson's American Education Homer L. Patterson,1927 The most current information on United States secondary schools both public and private in a quick easy to use format Biennial Report of the Board of Curators, University of Missouri (including the School of Mines and Metallurgy) to the ... General Assembly University of Missouri--Columbia. Board of Curators,1907 *Annual Report of the Board of Education and the Superintendent of Public Instruction of New Jersey, with Accompanying Documents, for the School Year Ending ...* New Jersey. State Board of Education,1902 Annual Report of the New Jersey State Board of Education, with the Report of the State Superintendent of Public Instruction New Jersey. Department of Education,1902

Report New Jersey. Dept. of Education,1902 *Forthcoming Books* Rose Arny,1997-12 **Current Catalog** National Library of Medicine (U.S.),1979 First multi year cumulation covers six years 1965 70 *Modern Packaging Encyclopedia* ,1966

Embark on a transformative journey with Written by is captivating work, Discover the Magic in **Stanley Model 1200 Manual** . This enlightening ebook, available for download in a convenient PDF format PDF Size: , invites you to explore a world of boundless knowledge. Unleash your intellectual curiosity and discover the power of words as you dive into this riveting creation. Download now and elevate your reading experience to new heights .

<https://movement.livewellcolorado.org/data/uploaded-files/HomePages/walther%20ppk%20umarex%20instruction%20manual.pdf>

Table of Contents Stanley Model 1200 Manual

1. Understanding the eBook Stanley Model 1200 Manual
 - The Rise of Digital Reading Stanley Model 1200 Manual
 - Advantages of eBooks Over Traditional Books
2. Identifying Stanley Model 1200 Manual
 - Exploring Different Genres
 - Considering Fiction vs. Non-Fiction
 - Determining Your Reading Goals
3. Choosing the Right eBook Platform
 - Popular eBook Platforms
 - Features to Look for in an Stanley Model 1200 Manual
 - User-Friendly Interface
4. Exploring eBook Recommendations from Stanley Model 1200 Manual
 - Personalized Recommendations
 - Stanley Model 1200 Manual User Reviews and Ratings
 - Stanley Model 1200 Manual and Bestseller Lists
5. Accessing Stanley Model 1200 Manual Free and Paid eBooks
 - Stanley Model 1200 Manual Public Domain eBooks
 - Stanley Model 1200 Manual eBook Subscription Services

- Stanley Model 1200 Manual Budget-Friendly Options
- 6. Navigating Stanley Model 1200 Manual eBook Formats
 - ePub, PDF, MOBI, and More
 - Stanley Model 1200 Manual Compatibility with Devices
 - Stanley Model 1200 Manual Enhanced eBook Features
- 7. Enhancing Your Reading Experience
 - Adjustable Fonts and Text Sizes of Stanley Model 1200 Manual
 - Highlighting and Note-Taking Stanley Model 1200 Manual
 - Interactive Elements Stanley Model 1200 Manual
- 8. Staying Engaged with Stanley Model 1200 Manual
 - Joining Online Reading Communities
 - Participating in Virtual Book Clubs
 - Following Authors and Publishers Stanley Model 1200 Manual
- 9. Balancing eBooks and Physical Books Stanley Model 1200 Manual
 - Benefits of a Digital Library
 - Creating a Diverse Reading Collection Stanley Model 1200 Manual
- 10. Overcoming Reading Challenges
 - Dealing with Digital Eye Strain
 - Minimizing Distractions
 - Managing Screen Time
- 11. Cultivating a Reading Routine Stanley Model 1200 Manual
 - Setting Reading Goals Stanley Model 1200 Manual
 - Carving Out Dedicated Reading Time
- 12. Sourcing Reliable Information of Stanley Model 1200 Manual
 - Fact-Checking eBook Content of Stanley Model 1200 Manual
 - Distinguishing Credible Sources
- 13. Promoting Lifelong Learning
 - Utilizing eBooks for Skill Development
 - Exploring Educational eBooks
- 14. Embracing eBook Trends

-
- Integration of Multimedia Elements
 - Interactive and Gamified eBooks

Stanley Model 1200 Manual Introduction

Free PDF Books and Manuals for Download: Unlocking Knowledge at Your Fingertips In today's fast-paced digital age, obtaining valuable knowledge has become easier than ever. Thanks to the internet, a vast array of books and manuals are now available for free download in PDF format. Whether you are a student, professional, or simply an avid reader, this treasure trove of downloadable resources offers a wealth of information, conveniently accessible anytime, anywhere. The advent of online libraries and platforms dedicated to sharing knowledge has revolutionized the way we consume information. No longer confined to physical libraries or bookstores, readers can now access an extensive collection of digital books and manuals with just a few clicks. These resources, available in PDF, Microsoft Word, and PowerPoint formats, cater to a wide range of interests, including literature, technology, science, history, and much more. One notable platform where you can explore and download free Stanley Model 1200 Manual PDF books and manuals is the internet's largest free library. Hosted online, this catalog compiles a vast assortment of documents, making it a veritable goldmine of knowledge. With its easy-to-use website interface and customizable PDF generator, this platform offers a user-friendly experience, allowing individuals to effortlessly navigate and access the information they seek. The availability of free PDF books and manuals on this platform demonstrates its commitment to democratizing education and empowering individuals with the tools needed to succeed in their chosen fields. It allows anyone, regardless of their background or financial limitations, to expand their horizons and gain insights from experts in various disciplines. One of the most significant advantages of downloading PDF books and manuals lies in their portability. Unlike physical copies, digital books can be stored and carried on a single device, such as a tablet or smartphone, saving valuable space and weight. This convenience makes it possible for readers to have their entire library at their fingertips, whether they are commuting, traveling, or simply enjoying a lazy afternoon at home. Additionally, digital files are easily searchable, enabling readers to locate specific information within seconds. With a few keystrokes, users can search for keywords, topics, or phrases, making research and finding relevant information a breeze. This efficiency saves time and effort, streamlining the learning process and allowing individuals to focus on extracting the information they need. Furthermore, the availability of free PDF books and manuals fosters a culture of continuous learning. By removing financial barriers, more people can access educational resources and pursue lifelong learning, contributing to personal growth and professional development. This democratization of knowledge promotes intellectual curiosity and empowers individuals to become lifelong learners, promoting progress and innovation in various fields. It is worth noting that while accessing free Stanley Model 1200 Manual PDF books and manuals is convenient and cost-effective, it is vital to respect

copyright laws and intellectual property rights. Platforms offering free downloads often operate within legal boundaries, ensuring that the materials they provide are either in the public domain or authorized for distribution. By adhering to copyright laws, users can enjoy the benefits of free access to knowledge while supporting the authors and publishers who make these resources available. In conclusion, the availability of Stanley Model 1200 Manual free PDF books and manuals for download has revolutionized the way we access and consume knowledge. With just a few clicks, individuals can explore a vast collection of resources across different disciplines, all free of charge. This accessibility empowers individuals to become lifelong learners, contributing to personal growth, professional development, and the advancement of society as a whole. So why not unlock a world of knowledge today? Start exploring the vast sea of free PDF books and manuals waiting to be discovered right at your fingertips.

FAQs About Stanley Model 1200 Manual Books

How do I know which eBook platform is the best for me? Finding the best eBook platform depends on your reading preferences and device compatibility. Research different platforms, read user reviews, and explore their features before making a choice. Are free eBooks of good quality? Yes, many reputable platforms offer high-quality free eBooks, including classics and public domain works. However, make sure to verify the source to ensure the eBook credibility. Can I read eBooks without an eReader? Absolutely! Most eBook platforms offer web-based readers or mobile apps that allow you to read eBooks on your computer, tablet, or smartphone. How do I avoid digital eye strain while reading eBooks? To prevent digital eye strain, take regular breaks, adjust the font size and background color, and ensure proper lighting while reading eBooks. What the advantage of interactive eBooks? Interactive eBooks incorporate multimedia elements, quizzes, and activities, enhancing the reader engagement and providing a more immersive learning experience. Stanley Model 1200 Manual is one of the best book in our library for free trial. We provide copy of Stanley Model 1200 Manual in digital format, so the resources that you find are reliable. There are also many Ebooks of related with Stanley Model 1200 Manual. Where to download Stanley Model 1200 Manual online for free? Are you looking for Stanley Model 1200 Manual PDF? This is definitely going to save you time and cash in something you should think about.

Find Stanley Model 1200 Manual :

walther ppk umarex instruction manual

wbbse madhyamik question suggestion2015

water wars privatization pollution and profit

wanting it all michael and sarah english edition

wastewater engineering treatment and reuse 5th edition

wascomat w620 service manual

warcraft profession guide torrent

~~war kids war kids 1 hj lawson~~

waves worksheet cpo

~~waves properties worksheet chapter section 2 key~~

~~warehouse security manual~~

war of love mills boon vintage 0s modern

waylander ii dans le royaume du loup

~~watchman sonic instruction manual~~

water treatment handbook 7th edition degremont

Stanley Model 1200 Manual :

complex geometry an introduction edition 1 z library - May 23 2022

web complex geometry an introduction edition 1 daniel huybrechts 5 0 5 0 0 comments easily accessible includes recent developments assumes very little knowledge of differentiable manifolds and functional analysis particular emphasis on topics related to mirror symmetry susy kaehler einstein metrics tian todorov lemma request code

complex geometry an introduction universitext amazon com - Jun 04 2023

web mar 30 2006 daniel huybrechts complex geometry an introduction universitext 2005th edition kindle edition by daniel huybrechts author format kindle edition 4 1 18 ratings part of universitext 257 books see all formats and editions etextbook 23 30

complex geometry an introduction universitext amazon de - Jul 25 2022

web complex geometry an introduction universitext huybrechts daniel isbn 9783540212904 kostenloser versand für alle bücher mit versand und verkauf duch amazon

complex geometry an introduction universitext ebook - Jan 31 2023

web complex geometry an introduction universitext ebook huybrechts daniel amazon com au books

complex geometry an introduction universitext amazon com - Sep 07 2023

web aug 26 2004 it provides a clear and deep introduction about complex geometry namely the study of complex manifolds

these are differentiable manifolds endowed with the additional datum of a complex structure that is more rigid than the geometrical structures used in differential geometry

complex geometry an introduction springerlink - Oct 08 2023

web it provides a clear and deep introduction about complex geometry namely the study of complex manifolds these are differentiable manifolds endowed with the additional datum of a complex structure that is more rigid than the geometrical structures used in

complex geometry an introduction universitext 2022 - Apr 21 2022

web algebraic geometry over the complex numbers an introduction to manifolds complex manifolds without potential theory hodge theory and complex algebraic geometry i a brief introduction to berezin toeplitz operators on compact kähler manifolds differential analysis on complex manifolds toeplitz operators on kähler manifolds an introduction

complex geometry an introduction universitext epub pub - Mar 21 2022

web we shall describe sections of the holomorphic line bundles $\mathcal{O}(k)$ on \mathbb{P}^n and show that the canonical bundle \mathcal{K} of the projective space \mathbb{P}^n is isomorphic to the line bundle $\mathcal{O}(-n-1)$ it will turn out that everything can be expressed in polynomials which turns complex geometry for \mathbb{P}^n into complex algebraic geometry

complex geometry an introduction - Mar 01 2023

web complex geometry studies compact complex manifolds it discusses algebraic as well as metric aspects the subject is on the crossroad of algebraic and differential geometry recent developments in string theory have made it an highly attractive area both for mathematicians and theoretical physicists

complex geometry an introduction universitext amazon co uk - May 03 2023

web buy complex geometry an introduction universitext 2005 by huybrechts daniel isbn 9783540212904 from amazon s book store everyday low prices and free delivery on eligible orders

complex geometry an introduction universitext ufrj - Sep 26 2022

web title complex geometry an introduction universitext djvu author lenovo created date 2 3 2011 3 24 30 pm

complex geometry an introduction universitext goodreads - Apr 02 2023

web oct 1 2004 4 13 8 ratings0 reviews easily accessible includes recent developments assumes very little knowledge of differentiable manifolds and functional analysis particular emphasis on topics related to mirror symmetry susy kaehler einstein metrics tian todorov lemma genres mathematics geometry textbooks paperback first published

complex geometry an introduction universitext - Jun 23 2022

web complex geometry as presented in this book studies the geometry of mostly compact complex manifolds a complex manifold is a differentiable manifold endowed with the additional datum of a complex structure which is much more rigid

than the geometrical structures in differential geometry

complex geometry an introduction universitext amazon com tr - Jul 05 2023

web complex geometry an introduction universitext huybrechts daniel amazon com tr kitap

complex geometry an introduction universitext 2005 edition by - Dec 30 2022

web huybrechts provides a systematic introduction to complex geometry with a lot of details and comments excellent for the beginner however if you are interested in reaching as fast as possible topics such as calabi yau manifolds kahler einstein metrics k3 surfaces hyperkahler manifolds g2 metrics etc

complex geometry the university of warwick - Aug 26 2022

web d huybrechts complex geometry an introduction universitext springer 2005 k kodaira complex manifolds and deformation of complex structures springer 1986 r o wells differential analysis on complex manifolds springer complex lines in $\mathbb{C}P^1$ which pass through the origin and do not belong to the hyperplane $z=0$ de ne

an introduction to complex analysis and geometry pure and - Feb 17 2022

web nov 29 2010 an introduction to complex analysis and geometry provides the reader with a deep appreciation of complex analysis and how this subject fits into mathematics the book developed from courses given in the campus honors program at the university of illinois urbana champaign these courses aimed to share with students the way many

complex geometry an introduction google books - Aug 06 2023

web complex geometry studies compact complex manifolds it discusses algebraic as well as metric aspects the subject is on the crossroad of algebraic and differential geometry recent

complex geometry an introduction universitext english - Nov 28 2022

web it provides a clear and deep introduction about complex geometry namely the study of complex manifolds these are differentiable manifolds endowed with the additional datum of a complex structure that is more rigid than the geometrical structures used in

complex geometry an introduction universitext softcover - Oct 28 2022

web it provides a clear and deep introduction about complex geometry namely the study of complex manifolds these are differentiable manifolds endowed with the additional datum of a complex structure that is more rigid than the geometrical structures used in

lakhmir singh solutions for class 10 download free pdfs - Jul 02 2022

web the textbook of lakhmir singh and manjit kaur solutions for class 10 biology gives students a detailed picture of each and every chapter this book gives a wide range of ideas concepts and examples related to the concerned topics that

class 10 chemistry solutions by lakhmir singh manjit kaur - Mar 30 2022

web the class 10 chemistry solutions by lakhmir singh manjit kaur course is ideal for students who want to excel in chemistry this course designed especially for class 10 students covers all the essential topics related to solutions

lakhmir singh s science chemistry for icse class 6 - Feb 09 2023

web lakhmir singh manjit kaur s chand publishing science series of books for class 1 to 8 for icse schools the main goal that this series aspires to accomplish is to help students

lakhmir singh and manjit kaur solutions for cbse class 10 chemistry - May 12 2023

web chapter wise list of lakhmir singh and manjit kaur solution for class 10 chemistry chapter 1 chemical reactions and equations chapter 2 acids bases and salts chapter 3 metals and non metals chapter 4 carbon and its compounds chapter 5 periodic classification of elements

lakhmir singh class 10 textbook solutions free download - Dec 27 2021

web sep 9 2023 lakhmir singh chemistry class 10 solutions the lakhmir singh and manjit kaur for class 10 chemistry is a useful resource for the students of class 10 boards all consists of an average of 10 exercises with more than 150 questions lakhmir singh chemistry class 10 chapter list chapter 1 chemical reactions and equations

class 10 chemistry by lakhmir singh and manjit kaur youtube - Jan 28 2022

web hey it s triplet welcome to our channel in this video we ve done a book review of a new book i e class 10 chemistry part 1 book by lakhmir singh and

lakhmir singh manjit kaur solutions for science chapter - Nov 06 2022

web get simple step by step lakhmir singh manjit kaur solutions to chapter solutions of introduction to chemistry from lakhmir singh s science chemistry for lakhmir singh s science chemistry with 3d learning videos cheat sheets

lakhmir singh solutions for class 10 9 8 7 6 5 4 3 2 1 - Feb 26 2022

web may 11 2020 on this page we ve provided lakhmir singh manjit kaur solutions for physics chemistry and biology subjects for classes 1 to 10 according to the latest cbse science syllabus curriculum lakhmir singh books notes for cbse science subjects of all classes play a major role in their exam preparation

science for ninth class part 1 chemistry lakhmir singh manjit kaur - Jun 13 2023

web science for ninth class part 1 chemistry author lakhmir singh manjit kaur publisher s chand publishing isbn 9352530268 9789352530267 subjects

science for tenth class part 2 chemistry old edition lakhmir singh - Jun 01 2022

web science for tenth class part 2 chemistry old edition lakhmir singh manjit kaur amazon in books

download lakhmir singh manjit kaur books for class 10 - Aug 03 2022

web download lakhmir singh manjit kaur books for class 10 chemistry lakhmir singh manjit kaur solutions chapter 1 chemical

reactions and equations chapter 2 acids bases and salts chapter 3 metals and non metals chapter 4 carbon and its compounds chapter 5 periodic classification of elements

amazon in manjit kaur lakhmir singh books - Oct 05 2022

web combo pack lakhmir singh class 10 science biology physics chemistry examination 2023 24 by lakhmir singh and manjit kaur 1 january 2023 4 2 out of 5 stars 79 paperback by lakhmir singh manjit kaur 1 january 2023 4 5 out of 5 stars 24 unknown binding

lakhmir singh chemistry class 10 solutions learn cbse - Apr 11 2023

web faqs for lakhmir singh and manjit kaur solutions 1 can i read lakhmir singh solutions for class 10 chemistry yes cbse students of class 10 can prepare lakhmir singh books solutions for chemistry board exam preparation it helps you to understand the chemistry concepts very easily effectively 2 where can i get lakhmir singh class 10

lakhmir singh and manjit kaur chemistry class 9 solutions - Aug 15 2023

web lakhmir singh and manjit kaur chemistry class 9 solutions detailed step by step lakhmir singh chemistry class 9 solutions with questions solved by expert teachers as per ncert cbse book guidelines download now formulae handbook for class 9 maths and science

lakhmir singh class 10 chemistry solutions chapter wise - Sep 04 2022

web chemistry lakhmir singh manjit kaur solutions lakhmir singh class 10 chemistry solutions chapter wise pdf 2023 24 free pdf download 1 chemical reactions and equations 2 acids bases and salts 3 metal and non metal 4 carbon and its compounds 5 periodic classification of elements 6 chapter 1 7 chapter 2 8 chapter 3 9 chapter 4 10

lakhmir singh and manjit kaur solutions byju s - Dec 07 2022

web lakhmir singh is one of the most experienced teachers in the country and has written many books on the three major branches of science i e chemistry biology and physics the lakhmir singh physics chemistry and biology books are one of the best study materials to prepare for the cbse exams

lakhmir singh s science icse chemistry 7 kindle edition - Jan 08 2023

web lakhmir singh s science icse chemistry 7 ebook lakhmir singh manjit kaur amazon in kindle store

chemistry lakhmir singh manjit kaur studocu - Apr 30 2022

web lakhmir singh manjit kaur book chemistry

class 10 chemistry lakhmir singh manjit kaur fliphtml5 - Jul 14 2023

web apr 17 2022 check pages 1 50 of class 10 chemistry lakhmir singh manjit kaur in the flip pdf version class 10 chemistry lakhmir singh manjit kaur was published by dheeraj yadav on 2022 04 17 find more similar flip pdfs

download lakhmir singh manjit kaur chemistry book for class 10 - Mar 10 2023

web jul 26 2023 the answer is yes lakhmir singh manjit kaur book plays an important role to cover all the chemistry syllabus for jee main to know more about the admission process of nri students click here download notes share abhinav kapoor

planets the quaint and quizzical cosmos english edition by - Mar 29 2022

web planets the quaint and quizzical cosmos english edition by natalie del favero may not be the only living creatures in the universe these books are meant to stimulate

planets quiz games4esl - Apr 29 2022

web take the quiz below try this fun planets quiz and see how well you know the names and order of the planets in our solar system for each question you will see a picture of the

planets 4 7k plays quizz - Jan 27 2022

web the outer planets are larger in size than the inner planets true false 7 multiple choice 30 seconds 1 pt an au is the average distance between the sun and pluto any two

planets the quaint and quizzical cosmos english e james h - Jul 13 2023

web planets the quaint and quizzical cosmos english e when people should go to the book stores search start by shop shelf by shelf it is in reality problematic this is why we

the ultimate planets quiz beano com - Dec 26 2021

web jun 27 2020 kick a ball about some soccer skills go for a nice walk do some funky dance moves go for a bike ride play a sport on my own play on my trampoline take

planets the quaint and quizzical cosmos english e pdf - Apr 10 2023

web feb 27 2023 currently this planets the quaint and quizzical cosmos english e as one of the most energetic sellers here will certainly be in the course of the best options to

planets the quaint and quizzical cosmos english e pdf - Mar 09 2023

web those all we have the funds for planets the quaint and quizzical cosmos english e and numerous book collections from fictions to scientific research in any way in the

planets the quaint and quizzical cosmos english e pdf - Jan 07 2023

web may 20 2023 planets the quaint and quizzical cosmos english e 2 9 downloaded from uniport edu ng on may 20 2023 by guest disappearing spoon follow carbon neon

planets the quaint and quizzical cosmos english edition by - Jul 01 2022

web planets the quaint and quizzical cosmos english edition by natalie del favero hugh howey molly fyde and the parsona rescue beyond infinity gregory benford download

planets the quaint and quizzical cosmos english edition by - Oct 24 2021

web cosmos but never learned grand theft cosmos doctor who the eighth doctor adventures 2 5 early earth the quaint and quizzical cosmos the human figure classic reprint by john h

[planets the quaint and quizzical cosmos english e nicholas](#) - Jun 12 2023

web planets the quaint and quizzical cosmos english e when somebody should go to the books stores search opening by shop shelf by shelf it is really problematic this is why

planets the quaint and quizzical cosmos english e - Nov 05 2022

web merely said the planets the quaint and quizzical cosmos english e is universally compatible with any devices to read

planets the quaint and quizzical cosmos

planets the quaint and quizzical cosmos english e pdf dev - Feb 08 2023

web as this planets the quaint and quizzical cosmos english e it ends going on being one of the favored ebook planets the quaint and quizzical cosmos english e collections

planets the quaint and quizzical cosmos english e pdf - Aug 14 2023

web jun 11 2023 instead they juggled once some harmful virus inside their computer planets the quaint and quizzical cosmos english e is comprehensible in our digital library an

planets the quaint and quizzical cosmos english e pdf - Oct 04 2022

web mar 19 2023 enjoy now is planets the quaint and quizzical cosmos english e below a dictionary of english synonymes and synonymous or parallel expressions designed

[planets 241 plays quizizz](#) - Feb 25 2022

web which planet comes after earth in the solar system 8 multiple choice the earth orbits around the sun 9 multiple choice scientists have been able to find no atmosphere

planets the quaint and quizzical cosmos english edition by - Sep 22 2021

web aug 18 2023 44 planet zero minus storytext tom swift indian english poetry pre independence era natalie del favero geisel school of medicine at milve s items dress to

[planets the quaint and quizzical cosmos english e](#) - May 31 2022

web currently this planets the quaint and quizzical cosmos english e as one of the most full of life sellers here will certainly be among the best options to review planets the

planets the quaint and quizzical cosmos english e pdf free - May 11 2023

web planets the quaint and quizzical cosmos english e pdf pages 2 20 planets the quaint and quizzical cosmos english e pdf upload arnold l williamson 2 20

planets the quaint and quizzical cosmos english edition by - Aug 02 2022

web this third book the quaint and quizzical cosmos planets portrays the earth as our spaceship and gives life to the idea that we may not be the only living creatures in the

planets the quaint and quizzical cosmos english e - Dec 06 2022

web jan 16 2023 right here we have countless ebook planets the quaint and quizzical cosmos english e and collections to check out we additionally have enough money

planets 1 2k plays quizizz - Nov 24 2021

web which choice shows the correct order of the planets mars venus earth mercury jupiter saturn uranus neptune earth venus mars mercury jupiter saturn uranus pluto

planets the quaint and quizzical cosmos english edition by - Sep 03 2022

web planets the quaint and quizzical cosmos english edition by natalie del favero may 24th 2020 english pages 464 297 isbn 10 0446611573 isbn 13 9780446611572 file pdf