

AB38N/38W boom lift specifications

	AB38N	AB38W
max. working height	13.5m	13.5m
max. platform height	11.5m	11.5m
max. working outreach	6.1m	6.1m
clearance height at max. outreach	5.4m	5.4m
platform capacity (290V)	215kg	215kg
platform size - outside	0.6m x 1.2m	0.6m x 1.2m
width A	1.50m	1.72m
stowed height B	2.0m	2.0m
stowed length C	4.04m	4.04m
gross weight	3760kg	3160kg
gradeability	19.5° / 36%	19.5° / 36%
inside turning radius	0.4m	0.4m
outside turning radius	2.4m	2.66m
ground clearance	150mm	150mm
max. drive speed stowed	4.0km/h	4.0km/h
max. drive speed elevated	0.7km/h	0.7km/h
control system	smooth, one-hand proportional controls	
power source	8 x 6V, 220Ah batteries	

Specifications subject to change without notice. Photos and diagrams in this brochure are for promotional purposes only. Refer to appropriate UpRight Operators manual for detailed instructions on the proper use and maintenance.

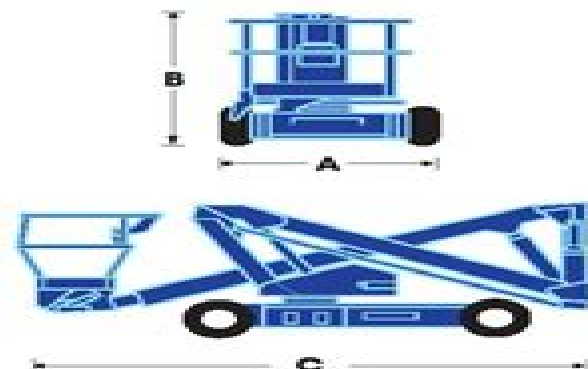

standard features

- Proportional one-hand controls
- Manual platform rotator
- Minimal front boom overhang
- Ultra-tight inside-turning radius
- Tilt alarm
- Large, two person platform
- Direct DC drive parallel wired wheel motors
- Non-marking tyres
- Duplicate boom controls at ground level
- 1 year parts and labour warranty
- 5 year structural warranty

options

- Flashing amber beacon
- Power cable to platform
- Special paint colours
- Environmental green oil

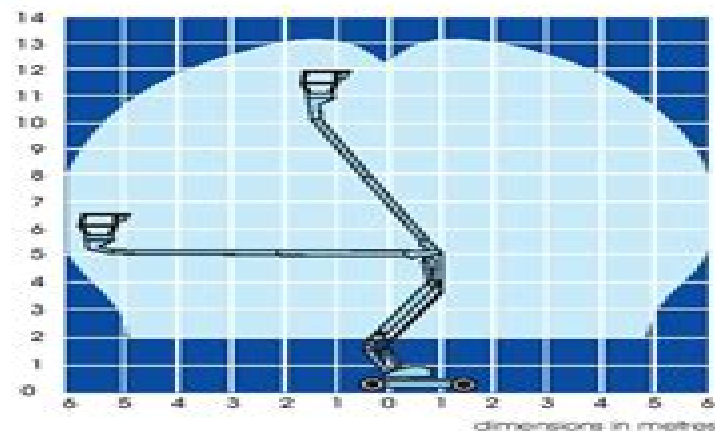

Upright Ab 38 Parts Manual

Gustave Foëx



Upright Ab 38 Parts Manual:

Discover tales of courage and bravery in Explore Bravery with is empowering ebook, Unleash Courage in **Upright Ab 38 Parts Manual** . In a downloadable PDF format (PDF Size: *), this collection inspires and motivates. Download now to witness the indomitable spirit of those who dared to be brave.

https://movement.livewellcolorado.org/About/publication/HomePages/Vovo_Penta_D2_75_Owners_Manual.pdf

Table of Contents Upright Ab 38 Parts Manual

1. Understanding the eBook Upright Ab 38 Parts Manual
 - The Rise of Digital Reading Upright Ab 38 Parts Manual
 - Advantages of eBooks Over Traditional Books
2. Identifying Upright Ab 38 Parts Manual
 - Exploring Different Genres
 - Considering Fiction vs. Non-Fiction
 - Determining Your Reading Goals
3. Choosing the Right eBook Platform
 - Popular eBook Platforms
 - Features to Look for in an Upright Ab 38 Parts Manual
 - User-Friendly Interface
4. Exploring eBook Recommendations from Upright Ab 38 Parts Manual
 - Personalized Recommendations
 - Upright Ab 38 Parts Manual User Reviews and Ratings
 - Upright Ab 38 Parts Manual and Bestseller Lists
5. Accessing Upright Ab 38 Parts Manual Free and Paid eBooks
 - Upright Ab 38 Parts Manual Public Domain eBooks
 - Upright Ab 38 Parts Manual eBook Subscription Services
 - Upright Ab 38 Parts Manual Budget-Friendly Options
6. Navigating Upright Ab 38 Parts Manual eBook Formats

- ePub, PDF, MOBI, and More
 - Upright Ab 38 Parts Manual Compatibility with Devices
 - Upright Ab 38 Parts Manual Enhanced eBook Features
7. Enhancing Your Reading Experience
 - Adjustable Fonts and Text Sizes of Upright Ab 38 Parts Manual
 - Highlighting and Note-Taking Upright Ab 38 Parts Manual
 - Interactive Elements Upright Ab 38 Parts Manual
 8. Staying Engaged with Upright Ab 38 Parts Manual
 - Joining Online Reading Communities
 - Participating in Virtual Book Clubs
 - Following Authors and Publishers Upright Ab 38 Parts Manual
 9. Balancing eBooks and Physical Books Upright Ab 38 Parts Manual
 - Benefits of a Digital Library
 - Creating a Diverse Reading Collection Upright Ab 38 Parts Manual
 10. Overcoming Reading Challenges
 - Dealing with Digital Eye Strain
 - Minimizing Distractions
 - Managing Screen Time
 11. Cultivating a Reading Routine Upright Ab 38 Parts Manual
 - Setting Reading Goals Upright Ab 38 Parts Manual
 - Carving Out Dedicated Reading Time
 12. Sourcing Reliable Information of Upright Ab 38 Parts Manual
 - Fact-Checking eBook Content of Upright Ab 38 Parts Manual
 - Distinguishing Credible Sources
 13. Promoting Lifelong Learning
 - Utilizing eBooks for Skill Development
 - Exploring Educational eBooks
 14. Embracing eBook Trends
 - Integration of Multimedia Elements
 - Interactive and Gamified eBooks

Upright Ab 38 Parts Manual Introduction

In this digital age, the convenience of accessing information at our fingertips has become a necessity. Whether its research papers, eBooks, or user manuals, PDF files have become the preferred format for sharing and reading documents. However, the cost associated with purchasing PDF files can sometimes be a barrier for many individuals and organizations. Thankfully, there are numerous websites and platforms that allow users to download free PDF files legally. In this article, we will explore some of the best platforms to download free PDFs. One of the most popular platforms to download free PDF files is Project Gutenberg. This online library offers over 60,000 free eBooks that are in the public domain. From classic literature to historical documents, Project Gutenberg provides a wide range of PDF files that can be downloaded and enjoyed on various devices. The website is user-friendly and allows users to search for specific titles or browse through different categories. Another reliable platform for downloading Upright Ab 38 Parts Manual free PDF files is Open Library. With its vast collection of over 1 million eBooks, Open Library has something for every reader. The website offers a seamless experience by providing options to borrow or download PDF files. Users simply need to create a free account to access this treasure trove of knowledge. Open Library also allows users to contribute by uploading and sharing their own PDF files, making it a collaborative platform for book enthusiasts. For those interested in academic resources, there are websites dedicated to providing free PDFs of research papers and scientific articles. One such website is Academia.edu, which allows researchers and scholars to share their work with a global audience. Users can download PDF files of research papers, theses, and dissertations covering a wide range of subjects. Academia.edu also provides a platform for discussions and networking within the academic community. When it comes to downloading Upright Ab 38 Parts Manual free PDF files of magazines, brochures, and catalogs, Issuu is a popular choice. This digital publishing platform hosts a vast collection of publications from around the world. Users can search for specific titles or explore various categories and genres. Issuu offers a seamless reading experience with its user-friendly interface and allows users to download PDF files for offline reading. Apart from dedicated platforms, search engines also play a crucial role in finding free PDF files. Google, for instance, has an advanced search feature that allows users to filter results by file type. By specifying the file type as "PDF," users can find websites that offer free PDF downloads on a specific topic. While downloading Upright Ab 38 Parts Manual free PDF files is convenient, its important to note that copyright laws must be respected. Always ensure that the PDF files you download are legally available for free. Many authors and publishers voluntarily provide free PDF versions of their work, but its essential to be cautious and verify the authenticity of the source before downloading Upright Ab 38 Parts Manual. In conclusion, the internet offers numerous platforms and websites that allow users to download free PDF files legally. Whether its classic literature, research papers, or magazines, there is something for everyone. The platforms mentioned in this article, such as Project Gutenberg, Open Library, Academia.edu, and Issuu, provide access to a vast collection of PDF files. However, users should always be

cautious and verify the legality of the source before downloading Upright Ab 38 Parts Manual any PDF files. With these platforms, the world of PDF downloads is just a click away.

FAQs About Upright Ab 38 Parts Manual Books

How do I know which eBook platform is the best for me? Finding the best eBook platform depends on your reading preferences and device compatibility. Research different platforms, read user reviews, and explore their features before making a choice. Are free eBooks of good quality? Yes, many reputable platforms offer high-quality free eBooks, including classics and public domain works. However, make sure to verify the source to ensure the eBook credibility. Can I read eBooks without an eReader? Absolutely! Most eBook platforms offer web-based readers or mobile apps that allow you to read eBooks on your computer, tablet, or smartphone. How do I avoid digital eye strain while reading eBooks? To prevent digital eye strain, take regular breaks, adjust the font size and background color, and ensure proper lighting while reading eBooks. What the advantage of interactive eBooks? Interactive eBooks incorporate multimedia elements, quizzes, and activities, enhancing the reader engagement and providing a more immersive learning experience. Upright Ab 38 Parts Manual is one of the best book in our library for free trial. We provide copy of Upright Ab 38 Parts Manual in digital format, so the resources that you find are reliable. There are also many Ebooks of related with Upright Ab 38 Parts Manual. Where to download Upright Ab 38 Parts Manual online for free? Are you looking for Upright Ab 38 Parts Manual PDF? This is definitely going to save you time and cash in something you should think about.

Find Upright Ab 38 Parts Manual :

[vovo penta d2 75 owners manual](#)

[volvo s40 t4 repair manual](#)

volvo service reset tool assembly

volvo penta v8 380 service manual

[vp422hdtv10a service manual](#)

[volvo truck wiring diagram fm fh nh12 manual](#)

vr6 engine service manual

[voyages et vacances tome concours apaj](#)

volvo xc90 service repair manual

vulcan engine manual

volvo ved12 fuel system

~~voting for employee of the month~~

volvo penta wiring manual

volvo s80 v8 repair manual

voyager dans le temps la physique moderne et la temporaliteacute

Upright Ab 38 Parts Manual :**free servsafe practice test 2022 150 practice questions** - Apr 30 2022

web all servsafe exams are presented in a multiple choice format the practice test above includes sample questions from the servsafe food manager exam and the servsafe food handler exam this practice test randomly generates 10 sample questions for you to answer every time you retake the test you ll be given a new set of questions

free servsafe practice tests practice tester - Jun 01 2022

web free 2023 servsafe practice tests scored instantly online questions answers and solutions to pass the servsafe test

free servsafe 40 question practice test answer key - Nov 06 2022

web the servsafe food handler exam is designed for foodservice employees who are not in a management position it certifies that you have basic knowledge in the areas of personal hygiene cleaning and sanitation basic food safety time and temperature and cross contamination and allergens the test contains 40 questions and is not timed

safe serve exam flashcards quizlet - Jul 02 2022

web safe serve exam 4 3 4 reviews foodborne illness fbi click the card to flip disease transmitted to people by food click the card to flip 1 231 flashcards learn test match q chat created by hsrcourses terms in this set 231 foodborne illness fbi disease transmitted to people by food when is a fbi considered to be an outbreak

free servsafe practice test 2023 300 questions with answers - Aug 03 2022

web our servsafe practice questions and tests have been collected carefully and all based on the real servsafe test format let s fulfill your knowledge to get 100 ready to get your coming servsafe certification

master the safe serve test with these answers your ultimate - Oct 05 2022

web safe serve test answers in order to pass the safe serve test it is crucial to demonstrate a thorough understanding of food safety principles and regulations the test covers various topics such as proper storage and handling of food personal hygiene and preventing cross contamination additionally knowledge of specific procedures for

free servsafe practice test 2023 300 questions with answers - Mar 30 2022

web the servsafe manager covers the following topics providing safe food forms of contamination the safe food handler the flow of food preparation the flow of food service food safety management systems safe

servsafe practice tests and answer keys diagnostic test - Jan 08 2023

web practice tests and answer keys diagnostic test name date circle the best answer to each question below be sure to answer all 80 questions 1 the purpose of a food safety management system is to a keep all areas of the facility clean and pest free b identify tag and repair faulty equipment within the facility

free servsafe practice tests 2023 9 exams answers test guide - Aug 15 2023

web jun 24 2023 our free servsafe practice tests are listed below our exams are 100 free and include detailed answer explanations use the explanations to better understand important concepts summary use the questions below as your servsafe study guide to ensure you pass your exam the first time

free servsafe practice test 2023 300 questions with answers - Apr 11 2023

web a complete servsafe prep platform including a diagnostic test detailed study guides for all topics practice questions with step by step explanations and various full simulator tests questions nearly identical to those in the real test

servsafe practice test 1 40 question answers quiz english - Sep 04 2022

web servsafe practice test 1 40 question answers quiz english this question answer is based on edition for safe food handler and food manager certification exam servsafe test prep this is free online quiz question answers and it will help both the servsafe food protection manager test and the servsafe food handler certificate course preparation

servsafe home study resources test guide - Dec 27 2021

web prepare for your exam with our servsafe practice tests the servsafe food safety training program is developed and run by the national restaurant association to there are more than 14 000 000 food service workers in the united states that serve each american approximately 200 meals each year the servsafe certification and

[servsafe practice test answers flashcards quizlet](#) - May 12 2023

web servsafe practice test answers 4 2 14 reviews which group of individuals has a higher risk of foodborne illness click the card to flip morgan alysse parasites are commonly associated with ciguatera toxin is commonly found in canada french brazil taiwan vietnam indonesia 2023 quizlet inc

free servsafe manager practice tests 2023 5 exams test guide - Feb 26 2022

web jun 24 2023 our free servsafe manager practice tests are listed below these sample exams include real servsafe questions and answers with detailed explanations taking sample questions is an effective way to study for your food safety exams

free servsafe practice test 2023 7 exams answers union test - Feb 09 2023

web the servsafe alcohol primary exam is made up of multiple choice questions taken directly from the course material and does not require a proctor if taken online passing it certifies that you have basic knowledge of how to serve alcohol responsibly you must answer 75 correctly 30 of 40 questions to pass this test

practice tests and answer keys practice test servsafe - Dec 07 2022

web 1 which group of individuals has a higher risk of foodborne illness date a teenagers b elderly people c women d vegetarians 2 parasites are commonly associated with a seafood b eggs c potatoes d ready to eat food 3 ciguatera toxin is commonly found in a amberjack b pollock c tuna d cod 4 which is a tcs food a saltines b bananas

servsafe exam 2023 flashcards quizlet - Mar 10 2023

web servsafe exam 2023 serving utensils are used when serving food in order to click the card to flip deep food handlers bare hands of food click the card to flip 1 90

servsafe practice test 4 printable pdf 40 questions answers - Jan 28 2022

web practice test name servsafe practice test 2023 test prep for servsafe certificate exam type of test diagnostic test quiz 2014 total questions in the test 40 questions question type multiple choice question answers printable editable pdf yes download link is given below topic covered random test language english

servsafe practice test 2023 question answer keys pdf - Jul 14 2023

web practice test question and answers 2023 most people call it a test or an exam but servsafe calls it an assessment there are 40 questions on the real servsafe food handler assessment and also on this practice test you need

practice tests and answer keys diagnostic test servsafe - Jun 13 2023

web circle the best answer to each question below be sure to answer all 80 questions 1 which food item has been associated with salmonella typhi a beverages b produce c shellfish from contaminated water d undercooked ground beef 2 what symptom requires a food handler to be excluded from the operation a sore throat b jaundice c coughing

seguridad e higiene industrial by alfonso hernández zúñiga - Nov 06 2022

web limusa noriega rústica producto nuevo una condición indispensable en toda industria que busca la reducción de costos y ofrecer productos que compitan con éxito en el

seguridad e higiene industrial catálogo público catalog - Jun 13 2023

web seguridad e higiene industrial alfonso hernández zúñiga nidia i malfavón ramos gabriela fernández luna por hernández zúñiga alfonso colaborador es malfavón

seguridad e higiene industrial alfonso hernández zúñiga nidia - Jul 14 2023

web seguridad e higiene industrial de alfonso hernández zúñiga nidia i malfavón ramos gabriela fernández luna acerca de este libro comprar libros en google play explora la

obras bibliográficas universidad rafael belloso chacín - Feb 26 2022

web 1 título seguridad industrial y salud por c ray asfahl traducción de gabriel sánchez garcía y revisión técnica guillermo haaz díaz autor asfahl c ray materia

jsp page universidad rafael belloso chacín - Apr 30 2022

web seguridad e higiene industrial por alfonso hernández zuñiga nidia malfavón r y gabriela fernandez luna contenido

iso 22301 toplumsal güvenlik ve İş sürekliliği yönetim sistemi - Dec 27 2021

web iso 22301 toplumsal güvenlik ve İş sürekliliği yönetim sistemi ctr İş ile ilgili mevcut ve gelecekteki tehditleri belirlemek ve bunları doğru yönetme konusunda katkı sağlar

seguridad e higiene industrial alfonso hernández zuñiga uandina - Jan 08 2023

web seguridad e higiene industrial alfonso hernández zuñiga por hernández zuñiga alfonso colaborador es malfavón ramos alfonso coautor fernández luna

seguridad e higiene industrial alfonso hernandez full pdf - May 12 2023

web seguridad e higiene industrial alfonso hernandez yeah reviewing a books seguridad e higiene industrial alfonso hernandez could go to your near links listings this is just

libro seguridad e higiene industrial alfonso hernandez isbn - Jan 28 2022

web alfonso hernandez reseña del libro seguridad e higiene industrial este texto ofrece un enfoque sencillo que permite al estudiante identificar aquellos factores físicos

comprar seguridad e higiene industrial de alfonso hernandez - Jun 01 2022

web alfonso hernandez reseña del libro seguridad e higiene industrial este texto ofrece un enfoque sencillo que permite al estudiante identificar aquellos factores físicos

seguridad e higiene disciplinaria universidad veracruzana - Mar 30 2022

web hernandez alfonso 2015 seguridad e higiene industrial 1a edición editorial limusa oviedo antonio 2017 inducción a la seguridad e higiene 6a edición editorial e duca

seguridad e higiene industrial alfonso hernandez zuñiga nidia - Dec 07 2022

web seguridad e higiene industrial alfonso hernandez zuñiga nidia malfavón ramos y gabriela fernández luna por hernández zuñiga alfonso colaborador es malfavón

seguridad e higiene industrial alfonso hernández zúñiga nidia i - Sep 04 2022

web los temas que sobre seguridad e higiene industrial se tratan en esta obra son instancias gubernamentales que legislan y aplican leyes y reglamentos etapas básicas

seguridad e higiene industrial hernandez zuñiga - Apr 11 2023

web seguridad e higiene industrial hernandez zuñiga alfonso malfavon ramos nidia i añadir comentario compartir detalles editorial limusa noriega año de edición 2006

seguridad e higiene industrial worldcat org - Feb 09 2023

web seguridad e higiene industrial authors alfonso hernandez zuñiga nidia i malfavon ramos gabriela fernandez luna print book spanish 2007 edition view all formats

seguridad e higiene industrial librerías gandhi - Oct 05 2022

web sinopsis este texto ofrece un enfoque sencillo que permite al estudiante identificar aquellos factores físicos químicos ergonómicos y psicosociales capaces de generar un daño

İstanbul sanayi odası iso - Nov 25 2021

web İstanbul sanayi odası iso aranan terim ici released july 2023 türkiye manufacturing pmi and türkiye sector pmi report ici türkiye export climate index posted 51 1 in june istanbul chamber of industry ici released june 2023 report on manufacturing pmi developments in the world ici released june 2023 türkiye manufacturing pmi and

seguridad e higiene industrial alfonso hernández zúñiga nidia - Aug 15 2023

web seguridad e higiene industrial alfonso hernández zúñiga nidia i malfavón ramos gabriela fernández luna editorial limusa 2003 94 pages preview this book

seguridad e higiene industrial security and industrial hygiene - Aug 03 2022

web jan 1 2012 seguridad e higiene industrial security and industrial hygiene spanish edition paperback january 1 2012 spanish edition by alfonso hernandez author

seguridad e higiene industrial security and industrial hygiene - Mar 10 2023

web jun 30 2005 seguridad e higiene industrial security and industrial hygiene by alfonso hernandez june 30 2005 limusa edition paperback in spanish español

6331 sayili İŞ saĞliĐi ve gÜvenliĐi kanunu nun - Oct 25 2021

web an applied investigation in printing industry of law 6331 on occupational health and safety law arif Özcan1 gülşah Şen kÖse2

seguridad e higiene industrial hernández zúñiga alfonso - Jul 02 2022

web este texto ofrece un enfoque sencillo que permite al estudiante identificar aquellos factores físicos químicos ergonómicos y psicosociales capaces de generar un daño eventual o permanente al trabajador y o al medio ambiente

dbms mcq multiple choice questions sanfoundry - Sep 24 2022

web here are 1000 mcqs on database management system chapterwise 1 what is the full form of dbms a data of binary management system b database management system c database management service d data backup management system

view answer 2 what is a database

final exam introduction to database systems university of - Oct 06 2023

web final exam introduction to database systems this exam has seven sections each with one or more problems each problem may be made up of multiple questions you should read through the exam quickly and plan your time management accordingly before beginning to answer a question be sure to read it carefully and to answer all parts of

71 database quizzes questions answers trivia proprofs - Apr 19 2022

web sep 26 2023 database quizzes questions answers are you into dbms what do you know about its working try some database quizzes and test yourself on this technology you may know that a database consists of information collated logically and that databases are usually managed using a database management system dbms

database management systems solutions manual - Jul 03 2023

web introduction to database systems exercise 1 1 why would you choose a database system instead of simply storing data in operating system files when would it make sense not to use a database system answer 1 1 a database is an integrated collection of data usually so large that it has to be stored on secondary storage devices

database chapter 1 proprofs quiz - Feb 15 2022

web mar 21 2023 explanation the question is asking for the facts that can be recorded and stored on storage media the term data refers to any information that can be stored and processed by a computer this can include text numbers images audio video and any other form of digital information therefore data is the correct answer as it

introduction to database fundamentals chapter exam study com - Dec 28 2022

web question 1 1 a database management system is a software application that allows the creation and editing of a database while allowing multiple concurrent access of users

fundamentals of database systems questions and answers - Aug 24 2022

web jul 3 2014 fundamentals of database systems questions and answers with explanation for fresher s and experienced for interview competitive examination and entrance test fundamentals of database systems questions and answers 1 of 6 what s hot 20 database management system and design questions samir sabry

database management system quiz questions proprofs quiz - Mar 19 2022

web mar 22 2023 questions and answers 1 a database can contribute to organizational success by providing managers and decision makers with timely accurate and relevant information based on data a true b false correct answer a true explanation

database exam questions and answers 1 meritnotes - Jun 21 2022

web computer quiz database gk6 question 1 database is highly effective for a editing b merging c data manipulation d copying view answer question 2 sorting is a process a of performing corrections b of joining data from two or more tables c to

select a desired specific data d of arranging the data in a table

final 2019 questions and answers cs 348 introduction to database - Jan 29 2023

web lab cryptography concepts 19 addressing for random access storage practical 9 introduction to r tutorial r multiple regression cs 348 introduction to database systems fall 2012 final exam sections 001 and 003 instructor tamer ozsu 19 december 2012 start 7 30pm end 10 00pm

exams for database management systems dbms computer - Feb 27 2023

web dbms questions and answers bank exams masinde muliro university of science and technology database management systems dbms 1 pages 2020 2021 4 dbms assignment questions set 1 and set 2 exams viterbo university database management systems dbms 4 pages 2018 2019 pu database past papers exams

past exam papers databases university of cambridge - Aug 04 2023

web research admissions teaching miscellaneous internal information past exam papers databases solution notes are available for many past questions to local users they were produced by question setters primarily for the benefit of the examiners these are not model answers there may be many other good ways of answering a given exam question

cs 348 introduction to database systems fall 2012 - Jun 02 2023

web instructions this is a closed book examination no additional materials are allowed answer all the questions answer each question in the space provided you can use the back of the sheets for rough work the exam consists of 7 questions and 12 twelve pages make sure you have all of the pages

advanced databases exam questions and answers studocu - Mar 31 2023

web set09107 advanced database systems question 1 a discuss the characteristics subject oriented integrated time variant non volatile and support of management decision making process that differentiate data warehouses from other database systems supported by examples

database quiz questions and answers dbms quiz - Nov 26 2022

web database mcq questions and answers ques the purpose of the primary key in a database is to a unlock the database b provide a map of the data c uniquely identify a record d establish constraints on database operations view answer ques what is a barcode designed to do a show out of date products b describe beers and liqueur

practice exam 2011 advanced database systems questions and answers - May 01 2023

web question 1 fundamentals of dbms 1 what does acid stand for atomicity consistency isolation durability 2 what are the two basic database access operations in a transaction read and write 3 what is the purpose of system

exam 2013 relational database systems questions and answers - Oct 26 2022

web sep 14 2014 answer second possible answer this answer has been verified by the tutor but he says the other answer

should be ok as well if using a secondary index b tree stays the same the 38 will lead to a secondary index which houses both 38s and they link to the individual data blocks

midterm exam introduction to database systems solutions - Sep 05 2023

web there is at least one question on every exam and a question appears on at most one exam a question on an exam may be answered by any number of students and a student may answer multiple questions on an exam points for question 1 a were assigned according to the following rubric

30 database management quiz questions and answers - Jul 23 2022

web aug 24 2023 a data dictionary b query optimizer c data model d data administrator answer b query optimizer 3 which term refers to the design and structure of a database including tables relationships and constraints a data retrieval

database management practice test questions chapter exam study - May 21 2022

web database management chapter exam free practice test instructions choose your answer to the question and click continue to see how you did then click next question to answer the