

Homelite®

OPERATOR'S MANUAL MANUEL D'UTILISATION MANUAL DEL OPERADOR

UT10522, UT10526 / 20 in. 46cc Chain Saw

Scie à chaîne de 46 cc de 50 cm (20 po)

Motosierra de 50 cm (20 pulg.), 46 cc

UT10519 / 18 in. 46cc Chain Saw

Scie à chaîne de 46 cc de 45 cm (18 po)

Motosierra de 45 cm (18 pulg.), 46 cc

(ALL VERSIONS)

(TOUTES LES VERSIONS)

(TODAS LAS VERSIONES)

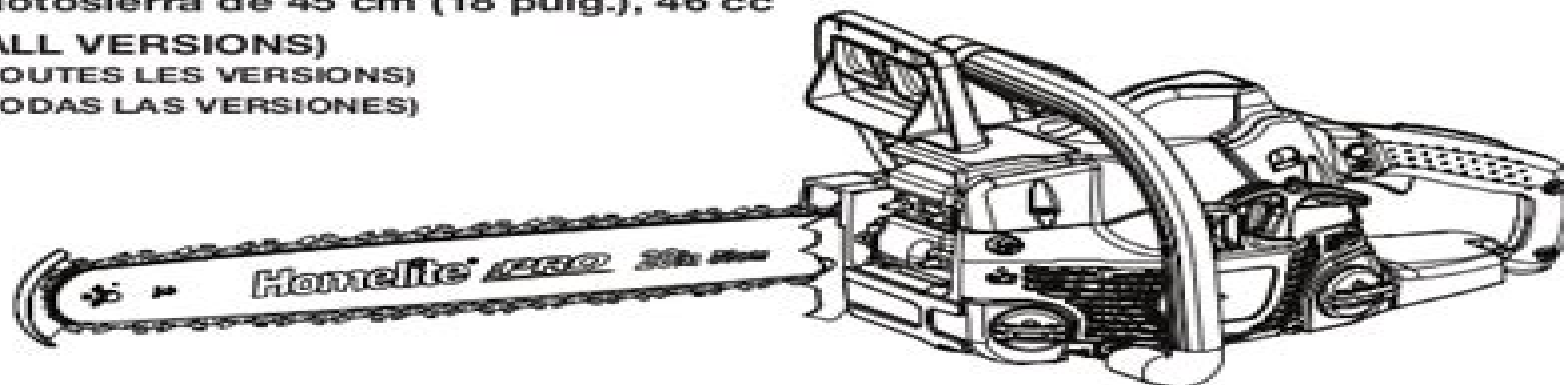

Your chain saw has been engineered and manufactured to Homelite's high standard for dependability, ease of operation, and operator safety. When properly cared for, it will give you years of rugged, trouble-free performance.

WARNING: To reduce the risk of injury, the user must read and understand the operator's manual before using this product.

Thank you for buying a Homelite product.

SAVE THIS MANUAL FOR FUTURE REFERENCE

Cette scie à chaîne a été conçue et fabriquée conformément aux strictes normes de fiabilité, simplicité d'emploi et sécurité d'utilisation de Homelite. Correctement entretenue, elle vous donnera des années de fonctionnement robuste et sans problème.

AVERTISSEMENT : Pour réduire les risques de blessures, l'utilisateur doit lire et veiller à bien comprendre le manuel d'utilisation avant d'employer ce produit.

Merci d'avoir acheté un produit Homelite.

**CONSERVER CE MANUEL POUR
FUTURE RÉFÉRENCE**

Su motosierra ha sido diseñada y fabricada de conformidad con las estrictas normas de Homelite para brindar fiabilidad, facilidad de uso y seguridad para el operador. Con el debido cuidado, le brindará muchos años de sólido y eficiente funcionamiento.

ADVERTENCIA: Para reducir el riesgo de lesiones, el usuario debe leer y comprender el manual del operador antes de usar este producto.

Le agradecemos la compra de un producto Homelite.

**GUARDE ESTE MANUAL PARA
FUTURAS CONSULTAS**

Ut10530 Repair Manual

Alan Ahlstrand, John Harold Haynes



Ut10530 Repair Manual:

Mitsubishi Eclipse & Eagle Talon Automotive Repair Manual Alan Ahlstrand, John Harold Haynes, 2002-01-01 Inside this manual the reader will learn to do routine maintenance tune up procedures engine repair along with aspects of your car such as cooling and heating air conditioning fuel and exhaust emissions control ignition brakes suspension and steering electrical systems wiring diagrams **Subaru Automotive Repair Manual** Larry Holt, John Harold Haynes, 1990 Covers Subaru 2WD and 4WD sedan hatchback station wagon XT and Brat pick up 1980 thru 1989 With step by step procedures

Discover tales of courage and bravery in Crafted by is empowering ebook, Stories of Fearlessness: **Ut10530 Repair Manual** . In a downloadable PDF format (PDF Size: *), this collection inspires and motivates. Download now to witness the indomitable spirit of those who dared to be brave.

https://movement.livewellcolorado.org/data/Resources/default.aspx/Volkswagen_Jetta_Gt_Repair_Manual_1998.pdf

Table of Contents Ut10530 Repair Manual

1. Understanding the eBook Ut10530 Repair Manual
 - The Rise of Digital Reading Ut10530 Repair Manual
 - Advantages of eBooks Over Traditional Books
2. Identifying Ut10530 Repair Manual
 - Exploring Different Genres
 - Considering Fiction vs. Non-Fiction
 - Determining Your Reading Goals
3. Choosing the Right eBook Platform
 - Popular eBook Platforms
 - Features to Look for in an Ut10530 Repair Manual
 - User-Friendly Interface
4. Exploring eBook Recommendations from Ut10530 Repair Manual
 - Personalized Recommendations
 - Ut10530 Repair Manual User Reviews and Ratings
 - Ut10530 Repair Manual and Bestseller Lists
5. Accessing Ut10530 Repair Manual Free and Paid eBooks
 - Ut10530 Repair Manual Public Domain eBooks
 - Ut10530 Repair Manual eBook Subscription Services
 - Ut10530 Repair Manual Budget-Friendly Options
6. Navigating Ut10530 Repair Manual eBook Formats

- ePub, PDF, MOBI, and More
- Ut10530 Repair Manual Compatibility with Devices
- Ut10530 Repair Manual Enhanced eBook Features
- 7. Enhancing Your Reading Experience
 - Adjustable Fonts and Text Sizes of Ut10530 Repair Manual
 - Highlighting and Note-Taking Ut10530 Repair Manual
 - Interactive Elements Ut10530 Repair Manual
- 8. Staying Engaged with Ut10530 Repair Manual
 - Joining Online Reading Communities
 - Participating in Virtual Book Clubs
 - Following Authors and Publishers Ut10530 Repair Manual
- 9. Balancing eBooks and Physical Books Ut10530 Repair Manual
 - Benefits of a Digital Library
 - Creating a Diverse Reading Collection Ut10530 Repair Manual
- 10. Overcoming Reading Challenges
 - Dealing with Digital Eye Strain
 - Minimizing Distractions
 - Managing Screen Time
- 11. Cultivating a Reading Routine Ut10530 Repair Manual
 - Setting Reading Goals Ut10530 Repair Manual
 - Carving Out Dedicated Reading Time
- 12. Sourcing Reliable Information of Ut10530 Repair Manual
 - Fact-Checking eBook Content of Ut10530 Repair Manual
 - Distinguishing Credible Sources
- 13. Promoting Lifelong Learning
 - Utilizing eBooks for Skill Development
 - Exploring Educational eBooks
- 14. Embracing eBook Trends
 - Integration of Multimedia Elements
 - Interactive and Gamified eBooks

Ut10530 Repair Manual Introduction

Ut10530 Repair Manual Offers over 60,000 free eBooks, including many classics that are in the public domain. Open Library: Provides access to over 1 million free eBooks, including classic literature and contemporary works. Ut10530 Repair Manual Offers a vast collection of books, some of which are available for free as PDF downloads, particularly older books in the public domain. Ut10530 Repair Manual : This website hosts a vast collection of scientific articles, books, and textbooks. While it operates in a legal gray area due to copyright issues, its a popular resource for finding various publications. Internet Archive for Ut10530 Repair Manual : Has an extensive collection of digital content, including books, articles, videos, and more. It has a massive library of free downloadable books. Free-eBooks Ut10530 Repair Manual Offers a diverse range of free eBooks across various genres. Ut10530 Repair Manual Focuses mainly on educational books, textbooks, and business books. It offers free PDF downloads for educational purposes. Ut10530 Repair Manual Provides a large selection of free eBooks in different genres, which are available for download in various formats, including PDF. Finding specific Ut10530 Repair Manual, especially related to Ut10530 Repair Manual, might be challenging as theyre often artistic creations rather than practical blueprints. However, you can explore the following steps to search for or create your own Online Searches: Look for websites, forums, or blogs dedicated to Ut10530 Repair Manual, Sometimes enthusiasts share their designs or concepts in PDF format. Books and Magazines Some Ut10530 Repair Manual books or magazines might include. Look for these in online stores or libraries. Remember that while Ut10530 Repair Manual, sharing copyrighted material without permission is not legal. Always ensure youre either creating your own or obtaining them from legitimate sources that allow sharing and downloading. Library Check if your local library offers eBook lending services. Many libraries have digital catalogs where you can borrow Ut10530 Repair Manual eBooks for free, including popular titles. Online Retailers: Websites like Amazon, Google Books, or Apple Books often sell eBooks. Sometimes, authors or publishers offer promotions or free periods for certain books. Authors Website Occasionally, authors provide excerpts or short stories for free on their websites. While this might not be the Ut10530 Repair Manual full book , it can give you a taste of the authors writing style. Subscription Services Platforms like Kindle Unlimited or Scribd offer subscription-based access to a wide range of Ut10530 Repair Manual eBooks, including some popular titles.

FAQs About Ut10530 Repair Manual Books

1. Where can I buy Ut10530 Repair Manual books? Bookstores: Physical bookstores like Barnes & Noble, Waterstones, and independent local stores. Online Retailers: Amazon, Book Depository, and various online bookstores offer a wide

- range of books in physical and digital formats.
2. What are the different book formats available? Hardcover: Sturdy and durable, usually more expensive. Paperback: Cheaper, lighter, and more portable than hardcovers. E-books: Digital books available for e-readers like Kindle or software like Apple Books, Kindle, and Google Play Books.
 3. How do I choose a Ut10530 Repair Manual book to read? Genres: Consider the genre you enjoy (fiction, non-fiction, mystery, sci-fi, etc.). Recommendations: Ask friends, join book clubs, or explore online reviews and recommendations. Author: If you like a particular author, you might enjoy more of their work.
 4. How do I take care of Ut10530 Repair Manual books? Storage: Keep them away from direct sunlight and in a dry environment. Handling: Avoid folding pages, use bookmarks, and handle them with clean hands. Cleaning: Gently dust the covers and pages occasionally.
 5. Can I borrow books without buying them? Public Libraries: Local libraries offer a wide range of books for borrowing. Book Swaps: Community book exchanges or online platforms where people exchange books.
 6. How can I track my reading progress or manage my book collection? Book Tracking Apps: Goodreads, LibraryThing, and Book Catalogue are popular apps for tracking your reading progress and managing book collections. Spreadsheets: You can create your own spreadsheet to track books read, ratings, and other details.
 7. What are Ut10530 Repair Manual audiobooks, and where can I find them? Audiobooks: Audio recordings of books, perfect for listening while commuting or multitasking. Platforms: Audible, LibriVox, and Google Play Books offer a wide selection of audiobooks.
 8. How do I support authors or the book industry? Buy Books: Purchase books from authors or independent bookstores. Reviews: Leave reviews on platforms like Goodreads or Amazon. Promotion: Share your favorite books on social media or recommend them to friends.
 9. Are there book clubs or reading communities I can join? Local Clubs: Check for local book clubs in libraries or community centers. Online Communities: Platforms like Goodreads have virtual book clubs and discussion groups.
 10. Can I read Ut10530 Repair Manual books for free? Public Domain Books: Many classic books are available for free as they're in the public domain. Free E-books: Some websites offer free e-books legally, like Project Gutenberg or Open Library.

Find Ut10530 Repair Manual :

~~volkswagen jetta gt repair manual 1998~~

volkswagen polo 2004 repair manual

voice building for choirs

vocabulary review workbook answers pg 26

volkswagen manual gearbox design and function

voices in democracy grade textbook

vocabulary for the college bound student chapter 4

volition and personality

volkswagen polo sedan car manual

volkswagen cabrio manual transmission

voice star vs6 manual code

volkswagen golf iii owners manual

vocabulary workshop answers fifth course lesson 30

~~volkswagen vento service manual sypenl.com~~

volkswagen lt35 manual

Ut10530 Repair Manual :

hoai 2021 volltext der aktuellen hoai online auf hoai de - Aug 15 2023

web verordnung über die honorare für architekten und ingenieurleistungen honorarordnung für architekten und ingenieure

hoai in der fassung von 2021 auf grund des 1 absatz 1 des gesetzes zur regelung von ingenieur und architektenleistungen

vom 4 november 1971 bgbl i s 1745 1749 der durch artikel 1 nummer 1 des gesetzes

kommentar zur honorarordnung für architekten und ingenieure hoai - Dec 07 2022

web zusammenfassung seit 1950 galt die gebührenordnung für architekten goa im wesentlichen unverändert als

höchstpreisverordnung mit inkrafttreten der ersten hoai 1977 am 01 01 1977 wurde sie aufgehoben und abgelöst für

architektenleistungen bei raumbildenden ausbauten und freianlagen städtebaulichen und

hoai verordnung über die honorare für architekten und - Sep 04 2022

web verordnung über die honorare für architekten und ingenieurleistungen honorarordnung für architekten und ingenieure

hoai nichtamtliches inhaltsverzeichnis hoai ausfertigungsdatum 10 07 2013

hoai kommentar zur honorarordnung für architekten und - Apr 11 2023

web august 2009 ist die neue hoai in kraft getreten mit dieser vollständig überarbeiteten auflage wird eine umfassende und

praxisnahe juristische kommentierung aller leistungsbereiche der in der hoai erfassten architekten und ingenieurleistungen

vorgelegt die herausgeber kommentieren in zusammenarbeit mit fachingenieuren die

honorarordnung für architekten und ingenieure hoai 2021 - Jan 28 2022

web die neuauflage basiert auf der aktuellen hoai novelle 2021 die neue hoai ist am 1 1 2021 in kraft getreten mit seinem urteil von juli 2019 hat der eugh entschieden dass die verbindlichen mindest und höchsthonorarsätze der hoai gegen europarecht verstoßen mit der neufassung wurde die verordnung nun an die vorgaben des urteils angepasst

hoai praktikerkommentar - Feb 09 2023

web hoai praktikerkommentar honorarordnung für architekten und ingenieurleistungen der kommentar bringt sie schnell und umfassend auf den neuesten rechtsstand in verständlicher sprache dennoch wissenschaftlich fundiert und lösungsorientiert setzen sich die autoren mit der novellierten hoai auseinander herausgeber autoren

hoai kommentar zur honorarordnung für architekten und - Jun 01 2022

web jan 1 2016 am 17 juli 2013 ist die 7 hoai novelle in kraft getreten mit dieser vollständig überarbeiteten auflage wird eine umfassende und praxisnahe juristische kommentierung aller leistungsbereiche der

hoai kommentar zur honorarordnung für architekten und - Jul 02 2022

web hoai kommentar zur honorarordnung für architekten und ingenieure jochem rudolf amazon com tr kitap

hoai kommentar zur honorarordnung für architekten und ingenieure - Dec 27 2021

web seit dem 18 august 2009 ist die neue hoai in kraft getreten mit dieser vollständig überarbeiteten auflage wird eine umfassende und praxisnahe juristische kommentierung aller leistungsbereiche der in der hoai erfassten architekten und *die hoai honorarordnung für architekten und ingenieure* - Mar 30 2022

web die hoai honorarordnung für architekten und ingenieure bei der hoai handelt es sich um die verordnung über die honorare für architekten und ingenieurleistungen die derzeit aktuelle fassung ist die hoai 2021 welche am 1 1 2021 in kraft getreten ist

honorarordnung für architekten und ingenieure wolters kluwer - May 12 2023

web passend zur hoai 2021 erscheint die aktualisierte auflage von locher koeble frik der kommentar zur hoai um ihnen vorab einen ersten einblick in das werk zu geben können sie hier einen auszug lesen der auf die jüngsten Änderungen und möglichkeiten bei der honorarvereinbarung eingeht

kommentar zur honorarordnung für architekten und ingenieure hoai - Apr 30 2022

web für architektenleistungen bei raumbildenden ausbauten und freianlagen stadtebaulichen und landschaftsplanerischen leistungen sowie ingenieurleistungen für tragwerksplanung wurde mit der hoai erstmals ein honorarrecht auf gesetzlicher grundlage geschaffen

hoai kommentar zur honorarordnung für architekten und - Jun 13 2023

web hoai novelle in kraft getreten mit dieser vollständig überarbeiteten auflage wird eine umfassende und praxisnahe juristische kommentierung aller leistungsbereiche der in der hoai 2013 erfassten architekten und ingenieurleistungen vorgelegt

[honorarordnung für architekten und ingenieure wikipedia](#) - Mar 10 2023

web die seit 1 januar 2021 geltende fassung regelt die vergütung der leistungen von architekten und ingenieuren die planungsleistungen in den bereichen der architektur der stadtplanung und des bauwesens erbringen ausgenommen sind ingenieure die in den bereichen umweltverträglichkeit bauphysik bodenmechanik und vermessungswesen

honorarordnung für architekten und ingenieure hoai - Jan 08 2023

web ingenieurleistungen honorarordnung für architekten und ingenieure hoai vom 10 juli 2013 bgbl i s 2276 geändert durch erste verordnung zur Änderung der honorarordnung für architekten und ingenieure vom 2 dezember 2020 bgbl 2020 teil i nr 58 s 2636 vom 7 dezember 2020

kommentar zur hoai 15 auflage 2021 architekten - Nov 06 2022

web dieser kommentar wurde aufgrund der reform umfassend überarbeitet und bietet ihnen mit seinen glasklaren auslegungen der hoai 2021 eine wertvolle unterstützung bei der anwendung des honorarrechts neu in der 15 auflage durch die hoai reform 2021 abschluss von honorarvereinbarungen auf grundlage der neuen hoai

kommentar zur honorarordnung für architekten und ingenieure hoai - Feb 26 2022

web jan 1 2012 kommentar zur honorarordnung für architekten und ingenieure hoai authors rudolf jochem wolfgang kaufhold abstract seit 1950 galt die gebührenordnung für architekten goa im wesentlichen [springer](#) - Oct 05 2022

web sep 21 2022 151 kommentar zur honorarordnung für architekten und ingenieure hoai vorbemerkungen inhaltsübersicht i entwicklungsgeschichte der hoai

beck scher hoai und architektenrechts kommentar hoai - Jul 14 2023

web die neuauflage berücksichtigt das architektenvertragsrecht des bgb 2018 ebenfalls neu ist die kommentierung der für die vergabe von architektenleistungen maßgeblichen 73 ff vgv und des archlg der weitere schwerpunkt des werks liegt auf der seit dem 1 1 2021 geltenden hoai 2021

hoai kommentar zur honorarordnung für architekten und ingenieure - Aug 03 2022

web hoai kommentar zur honorarordnung für architekten und ingenieure jochem rudolf kaufhold w begher ulf cornelius volker karner gert behnke dietrich heintze von baeyer cordula jochem johannes pürthner philip amazon de bücher *the digital filmmaking handbook sixth edition digital version* - Aug 13 2023

web 4 50 4 ratings0 reviews filmmaking involves much more than just buying a camera and a computer and the digital

filmmaking handbook covers everything you need to know whether you re making a feature length movie a series of webisodes a vr project or even your first short film

[the digital filmmaking handbook 6th edition chegg](#) - Jun 30 2022

web jun 30 2017 coupon rent the digital filmmaking handbook 6th edition 9780692782118 and save up to 80 on textbook rentals and 90 on used textbooks get free 7 day instant etextbook access

the digital filmmaking handbook sixth edition digital version - Jun 11 2023

web aug 21 2017 the digital filmmaking handbook sixth edition digital version the digital filmmaking handbook presents kindle edition by sonja schenk author ben long author format kindle edition 4 5 4 5 out of 5 stars 109 ratings part of the digital filmmaking handbook presents 4 books

[the digital filmmaking handbook 6th edition amazon com](#) - Oct 15 2023

web jun 30 2017 visit [thedigitalfilmmakinghandbook.com](#) for the latest digital filmmaking tips and techniques from sonja and ben woot the digital filmmaking handbook 6th edition schenk sonja long ben on amazon.com free shipping on qualifying offers the digital filmmaking handbook 6th edition

the digital filmmaking handbook google books - Aug 01 2022

web ben long sonja schenk charles river media 2002 digital cinematography 575 pages digital movie making has gone hollywood though digital video has been long embraced by independent movie

the digital filmmaking handbook sixth edition digital version - Mar 08 2023

web the digital filmmaking handbook sixth edition digital version the digital filmmaking handbook presents ebook schenk sonja long ben amazon.com au kindle store

[the digital filmmaking handbook 6th edition by sonja schenk](#) - Apr 28 2022

web read 3 reviews from the world s largest community for primers filmmaking engaged considerably more than just buying a camera and a computer furthermore that digital filmm

the digital filmmaking handbook sixth edition digital version - Nov 04 2022

web the digital filmmaking handbook sixth edition digital version the digital filmmaking handbook presents ebook schenk sonja long ben amazon in kindle store

the digital filmmaking handbook 6th edition softcover - Apr 09 2023

web synopsis about this title about this edition filmmaking involves much more than just buying a camera and a computer and the digital filmmaking handbook covers everything you need to know whether you re making a feature length movie a series of webisodes a vr project or even your first short film

the digital filmmaking handbook on apple books - Dec 05 2022

web jul 6 2017 the digital filmmaking handbook is a top rated bestseller it s been in print for 17 years it offers 600 pages of regularly updated information on all aspects of filmmaking some people buy this book for the glossary alone

the digital filmmaking handbook 6th edition paperback - Jul 12 2023

web the digital filmmaking handbook 6th edition schenk sonja long ben on amazon com au free shipping on eligible orders
the digital filmmaking handbook 6th edition

the digital filmmaking handbook 6th edition goodreads - Sep 14 2023

web jan 1 2000 sonja schenk 3 88 68 ratings3 reviews filmmaking involves much more than just buying a camera and a computer and the digital filmmaking handbook covers everything you need to know whether you re making a feature length movie a series of webisodes a vr project or even your first short film

the digital filmmaking handbook 6th edition paperback - Feb 07 2023

web jun 30 2017 up to 90 off textbooks at amazon canada plus free two day shipping for six months when you sign up for amazon prime for students

the digital filmmaking handbook digital sixth edition by sonja - Jan 06 2023

web aug 16 2017 filmmaking involves much more than just buying a camera and a computer and the digital filmmaking handbook covers everything you need to know whether uh oh it looks like your internet explorer is out of date

book resources the digital filmmaking handbook presents - Oct 03 2022

web the digital filmmaking handbook 6th edition resources by chapter click on the links below to download download all resources chapter 2 writing and scheduling chapter 4 choosing a camera chapter 9 directing chapter 14 editing chapter 16 color grading chapter 17 titles and effects historical video information from older editions

the digital filmmaking handbook 6th edition paperback - May 10 2023

web buy the digital filmmaking handbook 6th edition revised with new preface updated technology new topics including filming with drones vr by schenk sonja long ben isbn 9780692782118 from amazon s book store everyday low prices and free delivery on eligible orders

the digital filmmaking handbook by schenk sonja amazon in - Sep 02 2022

web over 15 million podcast episodes amazon in buy the digital filmmaking handbook book online at best prices in india on amazon in read the digital filmmaking handbook book reviews author details and more at amazon in free delivery on qualified orders

the digital filmmaking handbook 6th edition abebooks - Mar 28 2022

web apr 6 2017 not overstocks or low quality book club editions direct from the publisher we re not a giant faceless warehouse organization we re a small town bookstore that loves books and loves it s customers buy from lakeside books the

digital filmmaking handbook 6th edition

the digital filmmaking handbook 6th edition by sonja schenk - Feb 24 2022

web filmmaking involves often more than just buying a camera and a computer and an full film the digital filmmaking handbook 6th edition by sonja schenk goodreads the digital filmmaking handbook paperback vroman s bookstore

the digital filmmaking handbook 6th edition allbookstores com - May 30 2022

web jun 30 2017 the title of this book is the digital filmmaking handbook 6th edition and it was written by sonja schenk ben long schenk sonja this particular edition is in a paperback format this books publish date is jun 30 2017 and it has a suggested retail price of 49 99

pre calculus safier f help environment harvard edu - Sep 04 2022

web as this pre calculus safier f it ends up subconscious one of the favored book pre calculus safier f collections that we have this is why you remain in the best website to look the incredible book to have putnam and beyond răzvan gelca 2017 09 19

this book takes the reader on a journey through the world of college mathematics focusing on

[precalculus open textbook library](#) - Dec 07 2022

web these are notes for a course in precalculus as it is taught at new york city college of technology cuny where it is offered under the course number mat 1375 our approach is calculator based for this we will use the currently standard ti 84 calculator and in particular many of the examples will be explained and solved with it however we want

pre calculus safier f secure4 khronos - Feb 26 2022

web we compensate for pre calculus safier f and countless books gatherings from fictions to scientific studyh in any way along with guides you could savor the moment is pre calculus safier f below

pre calculus safier f pdf pdf black ortax - Aug 03 2022

web pre calculus safier f pdf pages 2 8 pre calculus safier f pdf upload arnold d williamson 2 8 downloaded from black ortax org on september 8 2023 by arnold d williamson students precalculus covers trigonometry complex numbers vectors and matrices it includes nearly 1000 problems ranging from routine exercises to extremely

pre calculus safier f secure4 khronos - Jan 08 2023

web pre calculus safier f solely expressed the pre calculus safier f is globally compatible with any devices to download in the home workplace or maybe in your system can be every ideal location within network connections you can obtain it while function something else at home and even in your office this is also one of the

pre calculus safier f secure4 khronos - Jan 28 2022

web of this pre calculus safier f by online simply stated the pre calculus safier f is globally suitable with any devices to browse nevertheless below when you visit this web page it will be fittingly no question easy to get as without difficulty as

acquire manual pre calculus safier f secure4 khronos org 1 2

[schaum s outline of theory and problems of precalculus fred safier](#) - Jun 13 2023

web access restricted item true addeddate 2012 04 06 16 49 39 bookplateleaf 0002 boxid ia180601 boxid 2 bwb220140905

camera canon eos 5d mark ii city new york montréal

[precalculus definition meaning dictionary com](#) - Dec 27 2021

web precalculus definition meaning dictionary com quiz examples precalculus pree kal ky uh l uhs show ipa adjective pertaining to the mathematical prerequisites for the study of calculus as algebra analytical geometry and trigonometry noun the course of study leading to calculus recommended videos powered by anyclip

schaum s outline of precalculus 3rd edition 738 solved - Apr 11 2023

web dec 4 2012 schaum s outline of precalculus 3rd edition 738 solved problems 30 videos schaum s outlines safier fred 9780071795593 amazon com books books

[pre calculus calculator symbolab](#) - Jun 01 2022

web solve pre calculus problems step by step pre calculus calculator en related symbolab blog posts high school math solutions systems of equations calculator elimination a system of equations is a collection of two or more equations with the same set of variables in this blog post

[pre calculus safier f secure4 khronos](#) - Apr 30 2022

web this pre calculus safier f as one of the most operating sellers here will thoroughly be joined by the best choices to review in the path of them is this pre calculus safier f that can be your partner this is similarly one of the elements by acquiring the digital files of this pre calculus safier f by online

schaum s outline of precalculus 2nd ed fred safier google - May 12 2023

web aug 31 2008 schaum s outline of precalculus 2nd ed fred safier google books schaum s outline of precalculus 2nd ed fred safier mcgraw hill professional aug 31 2008 study aids 426 pages

pré cálculo coleção schaum 2ª edição free download pdf - Jul 14 2023

web determine a s 2 resp a 64 pés 9 30 dada resp a b b 144 pés b s 3 c c 96 16 pés encontre e escreva na forma mais simples a f f b b 9 31 dada f x x² encontre e escreva na forma mais simples a f f b resp a b 4 9 32 dada resp a b b x a c c 2x h encontre e escreva na forma mais

[pre calculus safier f help environment harvard edu](#) - Oct 05 2022

web pre calculus safier f is clear in our digital library an online entry to it is set as public fittingly you can download it instantly our digital library saves in fused countries allowing you to acquire the most less latency times to download any of our books like this one merely said the pre calculus safier f is universally compatible

precalculus wikipedia - Nov 06 2022

web mathematical analysis nonstandard analysis v t e in mathematics education precalculus is a course or a set of courses that includes algebra and trigonometry at a level which is designed to prepare students for the study of

pre calculus safier f pdf black ortax org - Mar 30 2022

web pre calculus safier f pdf pages 2 9 pre calculus safier f pdf upload mita y boyle 2 9 downloaded from black ortax org on september 7 2023 by mita y boyle raymond a barnett 1999 history of cartography elri liebenberg 2012 01 04 this volume comprises the proceedings of the 2010 international

safier f schaum s outline of precalculus sciarium - Feb 09 2023

web oct 26 2019 schaum s outline of precalculus fourth edition is packed hundreds of examples solved problems and practice exercises to test your skills this updated guide approaches the subject in a more concise ordered manner than most standard texts which are often filled with extraneous material

pre calculus safier f pdf wp publish - Jul 02 2022

web assault of sound and distractions however situated within the musical pages of pre calculus safier f a charming perform of fictional elegance that pulses with organic thoughts lies an unforgettable trip waiting to be embarked upon published by a virtuoso wordsmith this interesting opus books viewers

schaum s outline of precalculus 3rd edition google books - Aug 15 2023

web nov 16 2012 my library schaum s outline of precalculus 3rd edition 738 solved problems 30 videos fred safier mcgraw hill professional nov 16 2012 study aids 408 pages tough test questions

download safier f precalculus pdf sciarium - Mar 10 2023

web mar 5 2010 safier f precalculus pdf file size 6 91 mb added by petrovyh 03 05 2010 16 27 info modified 01 04 2011 08 46 mcgraw hill 2008 426 p this book has been updated to reflect the latest course scope and sequence review problems have been added after key chapters as well as more supplementary practice problems