

# Pontiac G5 2005-2010 Workshop Manual

## Cylinder Head and Components

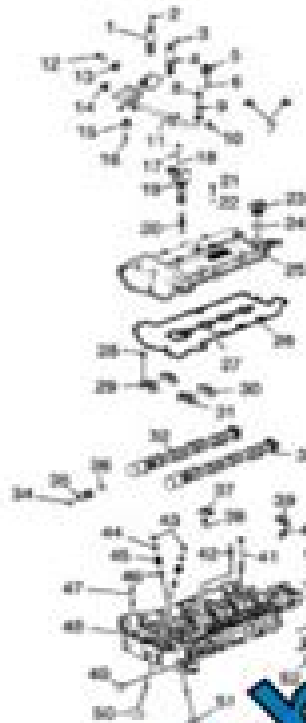

- (1) Camshaft Position Actuator - Intake Valve - Intake
- (2) Camshaft Position Actuator - Exhaust Valve Bolt
- (3) Camshaft Position Solenoid Valve Bolt
- (4) Camshaft Position Solenoid Valve - Exhaust
- (5) Upper Intake Manifold Sight Shield Grommet
- (6) Bell
- (7) Upper Intake Manifold Sight Shield Grommet
- (8) Turbocharger Coolant Feed Pipe Fitting
- (9) Turbocharger Coolant Feed Hose Gasket
- (10) Turbocharger Coolant Feed Hose Clamp
- (11) Turbocharger Coolant Feed Hose

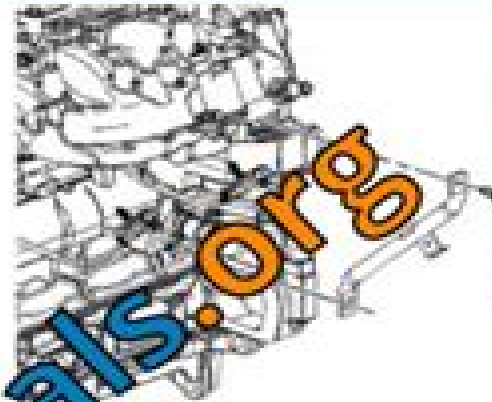

- 20. Disconnect the rear knock sensor from the intake manifold brace.
- 21. Remove the intake manifold brace bolt.
- 22. Remove the intake manifold brace.

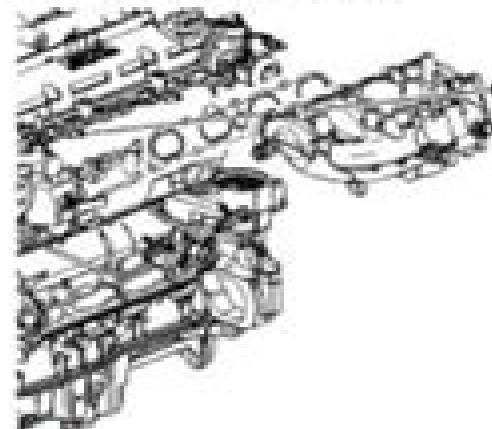

- 23. Remove the intake manifold bolts and nuts.
- 24. Remove the intake manifold.
- 25. Remove the intake manifold gasket.



workshopmanuals.org

# User Manual Pontiac G5 User Guide

**Ensheng Dong**



## **User Manual Pontiac G5 User Guide:**

Fuel Economy Guide ,2007 *The Garage Girl's Guide to Everything You Need to Know about Your Car* Courtney Hansen,2007 A guide to automobile ownership and maintenance discusses what kind of car to buy safety inspection fuel efficiency avoiding theft emergency supplies basic tools important car parts and how to deal with mechanics **The MG Enthusiast's Handbook** Pasquale De Marco,2025-08-11 This comprehensive guide to MG cars is the perfect resource for both seasoned enthusiasts and those new to the brand With its detailed information and engaging writing style this book will help you get the most out of your MG experience From its humble beginnings in the early 1900s to its heyday in the 1960s and 1970s MG has captured the hearts and imaginations of drivers all over the world In this book we take a deep dive into the history of MG exploring its iconic models and the people who made them possible We also provide all the information you need to keep your MG running in top condition From routine maintenance to troubleshooting and repairs we cover it all We also provide tips on how to modify your MG for improved performance Whether you re looking to learn more about the history of MG keep your current car in top condition or modify it for better performance this book is the perfect resource for you With its comprehensive coverage and engaging writing style this book is sure to please MG enthusiasts of all levels So sit back relax and enjoy the ride If you like this book write a review **Complete Guide for MAT and other MBA Entrance Exams 4th Edition** Disha Experts,2019-07-02 The thoroughly updated 4th Edition of the Complete Guide for MAT and other MBA entrance exams is specially designed for MBA entrance exam The USP of the book lies in its coverage of syllabus exhaustive theory techniques to master problem solving and Fully Solved exercises 1 The book contains Comprehensive Sections on Mathematical Skills English Language Data Analysis Sufficiency Intelligence and Critical Reasoning Indian and Global Environment 2 The book provides detailed theory along with exhaustive question bank in the form of exercise at the end of each chapter The solutions have been provided to each and every question 3 The Indian and Global Environment has been thoroughly revised and updated with latest current affairs including business questions as well The exercises has also been updated with latest questions 4 The book contains a lot of past MAT questions asked in the previous years To summarize the book is aimed to serve as one stop solution for all major MBA Entrance Exams CMAT NMAT SNAP MH CET IRMA ATMA ICET etc **Official Guide of the Railways and Steam Navigation Lines of the United States, Porto Rico, Canada, Mexico and Cuba** ,1946 The Official Guide of the Railways and Steam Navigation Lines of the United States, Puerto Rico, Canada, Mexico and Cuba William Frederick Allen,Edwin Stevens Allen,Andrew J. Burns,1947 Also time tables of railroads in Central America Air line schedules **Big-Block Chevy Performance** Dave Emanuel,1995 **Catholic Institutional Guide of Canada** ,1970 *Military Review* ,1930 **The Official Guide of the Railways and Steam Navigation Lines of the United States, Porto Rico, Canada, Mexico and Cuba** ,1897 **Hammond's Commercial and Library Atlas of the World** ,1912 **Hagstrom's Atlas and Official Postal Zone Guide of the City**

**of New York** Hagstrom Company,1966      *Bibliographic Guide to Maps and Atlases* ,2003      **Municipal Index** ,1926  
**The Official Guide of the Railways and Steam Navigation Lines of the United States, Porto Rico, Canada, Mexico and Cuba** ,1893 Also time tables of railroads in Central America Air line schedules      *The Encyclopædia Britannica* ,1911      **Automotive News** ,2008      Library Bulletin Fitchburg Public Library,1896      Popular Mechanics ,1996-08  
Popular Mechanics inspires instructs and influences readers to help them master the modern world Whether it s practical DIY home improvement tips gadgets and digital technology information on the newest cars or the latest breakthroughs in science PM is the ultimate guide to our high tech lifestyle      **Electrical Installation Record** ,1918

This book delves into User Manual Pontiac G5 User Guide. User Manual Pontiac G5 User Guide is a vital topic that needs to be grasped by everyone, from students and scholars to the general public. This book will furnish comprehensive and in-depth insights into User Manual Pontiac G5 User Guide, encompassing both the fundamentals and more intricate discussions.

1. This book is structured into several chapters, namely:

- Chapter 1: Introduction to User Manual Pontiac G5 User Guide
- Chapter 2: Essential Elements of User Manual Pontiac G5 User Guide
- Chapter 3: User Manual Pontiac G5 User Guide in Everyday Life
- Chapter 4: User Manual Pontiac G5 User Guide in Specific Contexts
- Chapter 5: Conclusion

2. In chapter 1, this book will provide an overview of User Manual Pontiac G5 User Guide. The first chapter will explore what User Manual Pontiac G5 User Guide is, why User Manual Pontiac G5 User Guide is vital, and how to effectively learn about User Manual Pontiac G5 User Guide.

3. In chapter 2, the author will delve into the foundational concepts of User Manual Pontiac G5 User Guide. The second chapter will elucidate the essential principles that need to be understood to grasp User Manual Pontiac G5 User Guide in its entirety.

4. In chapter 3, the author will examine the practical applications of User Manual Pontiac G5 User Guide in daily life. This chapter will showcase real-world examples of how User Manual Pontiac G5 User Guide can be effectively utilized in everyday scenarios.

5. In chapter 4, this book will scrutinize the relevance of User Manual Pontiac G5 User Guide in specific contexts. The fourth chapter will explore how User Manual Pontiac G5 User Guide is applied in specialized fields, such as education, business, and technology.

6. In chapter 5, the author will draw a conclusion about User Manual Pontiac G5 User Guide. This chapter will summarize the key points that have been discussed throughout the book.

The book is crafted in an easy-to-understand language and is complemented by engaging illustrations. It is highly recommended for anyone seeking to gain a comprehensive understanding of User Manual Pontiac G5 User Guide.

[https://movement.livewellcolorado.org/data/detail/fetch.php/the\\_step\\_rules\\_confession\\_english\\_edition.pdf](https://movement.livewellcolorado.org/data/detail/fetch.php/the_step_rules_confession_english_edition.pdf)

## **Table of Contents User Manual Pontiac G5 User Guide**

1. Understanding the eBook User Manual Pontiac G5 User Guide
  - The Rise of Digital Reading User Manual Pontiac G5 User Guide
  - Advantages of eBooks Over Traditional Books
2. Identifying User Manual Pontiac G5 User Guide
  - Exploring Different Genres
  - Considering Fiction vs. Non-Fiction
  - Determining Your Reading Goals
3. Choosing the Right eBook Platform
  - Popular eBook Platforms
  - Features to Look for in an User Manual Pontiac G5 User Guide
  - User-Friendly Interface
4. Exploring eBook Recommendations from User Manual Pontiac G5 User Guide
  - Personalized Recommendations
  - User Manual Pontiac G5 User Guide User Reviews and Ratings
  - User Manual Pontiac G5 User Guide and Bestseller Lists
5. Accessing User Manual Pontiac G5 User Guide Free and Paid eBooks
  - User Manual Pontiac G5 User Guide Public Domain eBooks
  - User Manual Pontiac G5 User Guide eBook Subscription Services
  - User Manual Pontiac G5 User Guide Budget-Friendly Options
6. Navigating User Manual Pontiac G5 User Guide eBook Formats
  - ePub, PDF, MOBI, and More
  - User Manual Pontiac G5 User Guide Compatibility with Devices
  - User Manual Pontiac G5 User Guide Enhanced eBook Features
7. Enhancing Your Reading Experience
  - Adjustable Fonts and Text Sizes of User Manual Pontiac G5 User Guide
  - Highlighting and Note-Taking User Manual Pontiac G5 User Guide
  - Interactive Elements User Manual Pontiac G5 User Guide
8. Staying Engaged with User Manual Pontiac G5 User Guide

- Joining Online Reading Communities
  - Participating in Virtual Book Clubs
  - Following Authors and Publishers User Manual Pontiac G5 User Guide
9. Balancing eBooks and Physical Books User Manual Pontiac G5 User Guide
- Benefits of a Digital Library
  - Creating a Diverse Reading Collection User Manual Pontiac G5 User Guide
10. Overcoming Reading Challenges
- Dealing with Digital Eye Strain
  - Minimizing Distractions
  - Managing Screen Time
11. Cultivating a Reading Routine User Manual Pontiac G5 User Guide
- Setting Reading Goals User Manual Pontiac G5 User Guide
  - Carving Out Dedicated Reading Time
12. Sourcing Reliable Information of User Manual Pontiac G5 User Guide
- Fact-Checking eBook Content of User Manual Pontiac G5 User Guide
  - Distinguishing Credible Sources
13. Promoting Lifelong Learning
- Utilizing eBooks for Skill Development
  - Exploring Educational eBooks
14. Embracing eBook Trends
- Integration of Multimedia Elements
  - Interactive and Gamified eBooks

### **User Manual Pontiac G5 User Guide Introduction**

User Manual Pontiac G5 User Guide Offers over 60,000 free eBooks, including many classics that are in the public domain. Open Library: Provides access to over 1 million free eBooks, including classic literature and contemporary works. User Manual Pontiac G5 User Guide Offers a vast collection of books, some of which are available for free as PDF downloads, particularly older books in the public domain. User Manual Pontiac G5 User Guide : This website hosts a vast collection of scientific articles, books, and textbooks. While it operates in a legal gray area due to copyright issues, its a popular resource for finding various publications. Internet Archive for User Manual Pontiac G5 User Guide : Has an extensive collection of

digital content, including books, articles, videos, and more. It has a massive library of free downloadable books. Free-eBooks User Manual Pontiac G5 User Guide Offers a diverse range of free eBooks across various genres. User Manual Pontiac G5 User Guide Focuses mainly on educational books, textbooks, and business books. It offers free PDF downloads for educational purposes. User Manual Pontiac G5 User Guide Provides a large selection of free eBooks in different genres, which are available for download in various formats, including PDF. Finding specific User Manual Pontiac G5 User Guide, especially related to User Manual Pontiac G5 User Guide, might be challenging as theyre often artistic creations rather than practical blueprints. However, you can explore the following steps to search for or create your own Online Searches: Look for websites, forums, or blogs dedicated to User Manual Pontiac G5 User Guide, Sometimes enthusiasts share their designs or concepts in PDF format. Books and Magazines Some User Manual Pontiac G5 User Guide books or magazines might include. Look for these in online stores or libraries. Remember that while User Manual Pontiac G5 User Guide, sharing copyrighted material without permission is not legal. Always ensure youre either creating your own or obtaining them from legitimate sources that allow sharing and downloading. Library Check if your local library offers eBook lending services. Many libraries have digital catalogs where you can borrow User Manual Pontiac G5 User Guide eBooks for free, including popular titles. Online Retailers: Websites like Amazon, Google Books, or Apple Books often sell eBooks. Sometimes, authors or publishers offer promotions or free periods for certain books. Authors Website Occasionally, authors provide excerpts or short stories for free on their websites. While this might not be the User Manual Pontiac G5 User Guide full book , it can give you a taste of the authors writing style. Subscription Services Platforms like Kindle Unlimited or Scribd offer subscription-based access to a wide range of User Manual Pontiac G5 User Guide eBooks, including some popular titles.

### **FAQs About User Manual Pontiac G5 User Guide Books**

How do I know which eBook platform is the best for me? Finding the best eBook platform depends on your reading preferences and device compatibility. Research different platforms, read user reviews, and explore their features before making a choice. Are free eBooks of good quality? Yes, many reputable platforms offer high-quality free eBooks, including classics and public domain works. However, make sure to verify the source to ensure the eBook credibility. Can I read eBooks without an eReader? Absolutely! Most eBook platforms offer webbased readers or mobile apps that allow you to read eBooks on your computer, tablet, or smartphone. How do I avoid digital eye strain while reading eBooks? To prevent digital eye strain, take regular breaks, adjust the font size and background color, and ensure proper lighting while reading eBooks. What the advantage of interactive eBooks? Interactive eBooks incorporate multimedia elements, quizzes, and activities, enhancing the reader engagement and providing a more immersive learning experience. User Manual Pontiac G5 User Guide



is one of the best book in our library for free trial. We provide copy of User Manual Pontiac G5 User Guide in digital format, so the resources that you find are reliable. There are also many Ebooks of related with User Manual Pontiac G5 User Guide. Where to download User Manual Pontiac G5 User Guide online for free? Are you looking for User Manual Pontiac G5 User Guide PDF? This is definitely going to save you time and cash in something you should think about. If you trying to find then search around for online. Without a doubt there are numerous these available and many of them have the freedom. However without doubt you receive whatever you purchase. An alternate way to get ideas is always to check another User Manual Pontiac G5 User Guide. This method for see exactly what may be included and adopt these ideas to your book. This site will almost certainly help you save time and effort, money and stress. If you are looking for free books then you really should consider finding to assist you try this. Several of User Manual Pontiac G5 User Guide are for sale to free while some are payable. If you arent sure if the books you would like to download works with for usage along with your computer, it is possible to download free trials. The free guides make it easy for someone to free access online library for download books to your device. You can get free download on free trial for lots of books categories. Our library is the biggest of these that have literally hundreds of thousands of different products categories represented. You will also see that there are specific sites catered to different product types or categories, brands or niches related with User Manual Pontiac G5 User Guide. So depending on what exactly you are searching, you will be able to choose e books to suit your own need. Need to access completely for Campbell Biology Seventh Edition book? Access Ebook without any digging. And by having access to our ebook online or by storing it on your computer, you have convenient answers with User Manual Pontiac G5 User Guide To get started finding User Manual Pontiac G5 User Guide, you are right to find our website which has a comprehensive collection of books online. Our library is the biggest of these that have literally hundreds of thousands of different products represented. You will also see that there are specific sites catered to different categories or niches related with User Manual Pontiac G5 User Guide So depending on what exactly you are searching, you will be able tochoose ebook to suit your own need. Thank you for reading User Manual Pontiac G5 User Guide. Maybe you have knowledge that, people have search numerous times for their favorite readings like this User Manual Pontiac G5 User Guide, but end up in harmful downloads. Rather than reading a good book with a cup of coffee in the afternoon, instead they juggled with some harmful bugs inside their laptop. User Manual Pontiac G5 User Guide is available in our book collection an online access to it is set as public so you can download it instantly. Our digital library spans in multiple locations, allowing you to get the most less latency time to download any of our books like this one. Merely said, User Manual Pontiac G5 User Guide is universally compatible with any devices to read.

**Find User Manual Pontiac G5 User Guide :**

**the step rules confession english edition**

**the soccer field is empty gay youth chronicles english edition**

the similarities of funza lushaka and nfsas

the story of freginald freddy the pig

**the talisman daughters of the moon book 10**

**the sacred shore moon island book english edition**

**the survival guide to zombies**

the song in observe and report trailer

**the stranger af albert camus**

the sanford guide to antimicrobial therapy 2012 guide to antimicro

**the state of the universe a primer in modern cosmology**

**the secret to winning gin**

the seeds of new earth the silent earth book 2

the summary of the dube train

the snake s pass fantastic forgotten volume 1

**User Manual Pontiac G5 User Guide :**

the triola statistics series pearson - Oct 25 2021

*elementary statistics 13th edition mario f triola* - Jan 08 2023

web feb 19 2021 elementary statistics home statistics introductory statistics elementary statistics i m a student i m an educator elementary statistics 14th edition published

**elementary statistics 13th edition textbook solutions** - Mar 10 2023

web elementary statistics 12th edition isbn 9780321836960 alternate isbns mario f triola textbook solutions verified chapter 1 introduction to statistics section 1 2 statistical

elementary statistics 13th edition triola solutions - Oct 05 2022

web elementary statistics 12th edition triola mario f publisher pearson isbn 978 0 32183 696 0

**elementary statistics 13th edition worldcat org** - Sep 23 2021

*elementary statistics triola flashcards quizlet* - Jul 02 2022

web jul 14 2021 isbn 13 9780137366446 elementary statistics published 2021 need help

**elementary statistics using excel 6th edition course hero** - Dec 27 2021

elementary statistics 13th edition solutions course hero - May 12 2023

web elementary statistics 9th edition isbn 9780201775709 mario f triola textbook solutions verified chapter 1 introduction to statistics section 1 2 types of data

**elementary statistics solutions manual triola mario** - Sep 04 2022

web dec 31 2016 mylab statistics with pearson etext 18 weeks for elementary statistics published 2019 need help get in touch products pearson study tools mario f

**elementary statistics 14th edition solutions and answers** - Jul 14 2023

web our resource for elementary statistics includes answers to chapter exercises as well as detailed information to walk you through the process step by step with expert solutions

**elementary statistics pearson** - Mar 30 2022

web renowned author marty triola uses an unparalleled amount of current real data to help students of all majors understand the role of statistics in their lives fostering their

**elementary statistics mario f triola google books** - Nov 25 2021

**triolastats** - Feb 26 2022

web elementary statistics 13th edition authors mario f triola laura iossi contributor summary from opinion polls and clinical trials to self driving cars statistics influences and shapes the world around us

**elementary statistics 12th edition solutions and answers** - Dec 07 2022

web chapter 1 terms in this set 37 data collections of observations statistics science of planning studies experiments and obtaining data then organizing summarizing

**textbook answers gradesaver** - Apr 30 2022

web mario f triola is a professor emeritus of mathematics at dutchess community college where he has taught statistics for over 30 years marty is the author of essentials of

**elementary statistics 9th edition solutions and answers quizlet** - Feb 09 2023

web step by step video answers explanations by expert educators for all elementary statistics 12th by mario f triola only on numerade com

**solutions for elementary statistics 13th by mario f triola book** - Jun 13 2023

web our resource for elementary statistics includes answers to chapter exercises as well as detailed information to walk you through the process step by step with expert solutions

*solutions for elementary statistics 12th by mario f triola book* - Nov 06 2022

web aug 8 2012 mario triola s elementary statistics remains the market leading introductory statistics textbook because it engages readers with an abundance of real data in the

**elementary statistics 13th edition solutions and answers** - Aug 15 2023

web elementary statistics 13th edition isbn 9780134462455 alternate isbns mario f triola textbook solutions verified chapter 1 introduction to statistics section 1 1 statistical

*elementary statistics mario f triola google books* - Jun 01 2022

web access the complete solution set for triola s elementary statistics using excel 6th edition

**elementary statistics 11th edition solutions and answers** - Apr 11 2023

web textbook solutions for elementary statistics 13th edition 13th edition mario f triola and others in this series view step by step homework solutions for your homework ask our

*elementary statistics pearson* - Aug 03 2022

web triola stats creates the most effective tools for statistics education including the market leading triola series textbooks visit us to learn more

*elementary statistics pearson* - Jan 28 2022

*learning and training tan tock seng hospital* - Apr 13 2023

web nov 8 2023 training and capability building for long term and palliative care through a mix of tutorials and practical coaching ttsh provides tailored training programmes that

*tshepong hospital learnership darelova* - Jun 03 2022

web may 18 2023 tshepong hospital learnership tshepong hospital learnership jobs in phuthaditjhaba careers amp vacancies in north west department of health vacancies

**tshepong hospital learnership thegreenroute com** - May 02 2022

web tshepong hospital learnership downloaded from thegreenroute com by guest skinner devan the national aids strategy white house office a faith based 12 step

*tshepong hospital learnership orientation sutd edu sg* - Jun 15 2023

web tshepong hospital learnership tshepong hospital learnership jobs in phuthaditjhaba careers amp vacancies in north west

department of health vacancies govpage

**tshepong hospital learnership help environment harvard edu** - Nov 27 2021

web tshepong hospital learnership if you ally compulsion such a referred tshepong hospital learnership books that will meet the expense of you worth get the entirely

**tshepong hospital learnership edms ncdmb gov ng** - Apr 01 2022

web title tshepong hospital learnership author edms ncdmb gov ng 2023 09 22 06 54 05 subject tshepong hospital learnership keywords tshepong hospital learnership

**healthcare sector to offer 7 500 jobs 1 600 traineeships** - Oct 19 2023

web aug 25 2020 singapore about 7 500 jobs and 1 600 traineeships attachments and skills training opportunities will be available from now until end 2021 in the healthcare

**tshepong hospital learnership download only** - Feb 11 2023

web tshepong hospital learnership the history of the development of nursing in south africa 1652 1960 jan 07 2023 2021 ieee international conference on sensors and

**updates regarding electives in singapore ttsh sip for 2016** - Dec 09 2022

web aug 17 2015 the attachment will expose students to the expectations of a house officer in the singapore healthcare system and ensure that combination of ward work and on call

ebook tshepong hospital learnership - Jan 10 2023

web tshepong hospital learnership this is likewise one of the factors by obtaining the soft documents of this tshepong hospital learnership by online you might not require

*tshepong hospital learnership download only* - Dec 29 2021

web tshepong hospital learnership beyond memory jul 11 2023 south africa possesses one of the richest popular music traditions in the world from marabi to mbaqanga from

*pre professional education ppeo tan tock seng hospital* - Sep 18 2023

web nov 8 2023 pre professional refers to allied health medical nursing and pharmacy students from ite polytechnics and universities who have not graduated from their

**tshepong hospital learnership 2015eeglobalsip** - Nov 08 2022

web apr 7 2023 tshepong hospital learnership right here we have countless books tshepong hospital learnership and collections to check out we additionally meet the

**tshepong hospital learnership yvc moeys gov kh** - Jan 30 2022

web tshepong hospital learnership this is likewise one of the factors by obtaining the soft documents of this tshepong hospital

learnership by online you might not require

*jobs in phuthaditjhaba careers amp vacancies in north west* - Mar 12 2023

web tshepong hospital learnership search jobs and careers in phuthaditjhaba find employment by browsing our list of vacancies in phuthaditjhaba north west

**tshepong hospital learnership zapmap nissan co** - Sep 06 2022

web 4 tshepong hospital learnership 2021 11 27 topics as power policy and the city of london and the role of the cbi in representing capital major theoretical themes are also

*tshepong hospital learnership online kptm edu my* - Aug 05 2022

web tshepong hospital learnership north west department of health vacancies govpage co za jobs in phuthaditjhaba careers amp vacancies in north west

**scholarships and sponsorships tan tock seng hospital** - May 14 2023

web career choices scholarships and sponsorships student opportunities healthcare management associate programme ttsh internship programme publications refer to

student opportunities tan tock seng hospital singapore - Aug 17 2023

web at ttsh we believe in offering students of different educational levels and background to discover their passion and help unleash their potential in building a future career with us

**tshepong hospital learnership** - Feb 28 2022

web aug 19 2023 tshepong hospital learnership author rhur impacthub net 2023 08 19 13 26 22 subject tshepong hospital learnership keywords

ttsh internship programme tan tock seng hospital singapore - Jul 16 2023

web nov 8 2023 the ttsh internship programme provides undergraduates with a head start on a career in healthcare through experiential hands on learning project assignments

**tshepong hospital learnership jmssenioreliving** - Oct 07 2022

web tshepong hospital learnership fifth report hospital training school methods and the head nurse hospital doctors workshops on education and training of occupational

**tshepong hospital learnership leadership kingsley edu my** - Jul 04 2022

web title tshepong hospital learnership author leadership kingsley edu my 2023 10 28 05 57 15 subject tshepong hospital learnership keywords

*general arrangement pdf ships fire sprinkler system scribd* - Dec 26 2021

web ship general arrangement cable ship liululu net keywords work boats for sale at plymouth ship brokerage plymouth lcs

the usa s littoral combat ships ship

**designing a new level of performance rolls royce** - Jun 12 2023

web a well designed ship is a result of collaboration experience innovation and state of the art equipment general arrangement visualisations presentations vessel specification

**procedure for designing a ship s general arrangement** - May 11 2023

web friendly designs for cable arrangement on the deck side of offshore vessels three credible options were identified acableway arrangement on the main deck alone the

*ship general arrangement cable ship help discoveram* - Oct 24 2021

**ship general arrangement cable ship liululu** - Sep 22 2021

introduction to ship general arrangement and construction - Jul 01 2022

web merely said the ship general arrangement cable ship is universally compatible with any devices to read instruction manual westinghouse air brake company marine division

*decision making for cable routing at detailed ship design through* - Apr 10 2023

web in summary the current problem in terms of ship design and buildings as well as cable design is that there is some room to optimize ship design and construction to reduce the

ship general arrangement cable ship download only - Oct 04 2022

web systems and ship structural arrangement understand the systems and ship s structural arrangement for the following merchant ship types container ship oil tanker lng

**naval architecture design hull shipbuilding britannica** - Jan 07 2023

web cable supported composite bridges may 31 2023 this book introduces the latest developments in long span cable supported composite cable stayed bridges

general arrangement of ship download scientific diagram - Jan 27 2022

web may 19 2023 ship general arrangement cable ship termination cable connecting plug 12 10 insert arrangement 12 shell size 10 contacts amphenol industrial pt01a

**naval architectural drawings and plans springerlink** - Feb 08 2023

web general arrangement features by ship type a brief tabulation of principal ship types serves to highlight the arrangement features characteristic of each

how to design a ship creating a general arrangement youtube - May 31 2022

web the design developed in the dissertation is based on the conceptual design of general containership b 178 built in the stocznia szczecińska nowa providing its main

[ship general arrangement cable ship copy monograf](#) - Nov 24 2021

web 2 days ago airpods pro 2nd generation with magsafe charging case usb c will enable lossless audio with ultra low latency to deliver the perfect true wireless solution

[ship general arrangement cable ship book](#) - Mar 29 2022

web general arrangement free download as pdf file pdf or read online for free the general arrangement of a ship can be defined as the assignment of wa 17800 kg

[decision making for cable routing at detailed ship design](#) - Mar 09 2023

web jan 1 2014 general overview plans general arrangement of spaces and outfitting capacity plan loading plan plans of piping cabling systems general construction

**what is ga or general arrangement plan and information** - Apr 29 2022

web the new general arrangement drawing is in fig 1 new specifications 1 and insulation plans fire thermal and noise insulation for the different ship versions were

**guidelines on high voltage shore connection systems irclass** - Sep 03 2022

web sep 12 2022 how to design a ship not an easy question to create a general arrangement drawing you need to first design all the major parts of the ship the real qu

[ship general arrangement cable ship download only](#) - Aug 02 2022

web feb 24 2020 general cargo ships usually have the capability of carrying some containers within the line of hatches and this will lead to hatch dimensions tending to be a multiple of

[ntt world engineering marine corporation cable](#) - Dec 06 2022

web mooring arrangements etc general arrangement showing location of connection equipment cabinets cable routing etc type testing of plugs sockets cables etc

[ship ga general arrangement deck plan drawing](#) - Nov 05 2022

web preliminary examination for a ship canal from the great lakes to the navigable waters of the hudson river the shipbuilder and marine engine builder transactions the society

**lecture 6 ship general arrangement ga aalto** - Aug 14 2023

web the design of a ship s general arrangement is a continuous and iterative process that starts with concept design and is changing through different design phases this is because ga is affected by the positioning of engineering systems and structural design



**apple upgrades airpods pro 2nd generation with usb c charging** - Aug 22 2021

**structural design of a container ship approximately 3100 teu** - Feb 25 2022

web ship general arrangement cable ship 1 ship general arrangement cable ship eventually you will extremely discover a other experience and achievement by spending

**the ultimate approach for general arrangement definition** - Jul 13 2023

web oct 22 2014 the general arrangement of a vessel can be defined as the allocation of volumes for all the crucial functions operations correctly synchronized for position and